



ZARGES
Professional



Operating Instructions

Issue 2000/2001

GB

N° 290914

Dear Customer,

Please record the missing information in the field below. This information will facilitate your communication with the manufacturer in case of questions.

<p>Type/Order No.:</p> <p>Year built:</p> <p>Consecutive No.:</p> <p>Date of delivery:</p>
--

If you desire further information, or if any problems occur that have not been treated in sufficient detail in this manual, you can request the necessary information directly from the manufacturer (see section 1.2).

We also point out that the contents of this operating manual are not subject to any earlier existing agreements, promises or any legal relationships and do not modify these in any way. All obligations ensue from the particular sales contract that also contains the complete and solely valid terms of warranty (see also section 1.4). These contractual terms of warranty are neither extended nor restricted by this operating manual.

Transmission and reproduction of this document, utilisation and disclosure of its contents are allowed only with the express approval of the manufacturer. Any violations will require payment of damages.

Table of Contents		Page
1	GENERAL	1
1.1	Introduction	1
1.2	Manufacturer	1
1.3	Homologation	1
1.4	Issue No. and/or date of issue	2
1.5	Copyrights	2
1.6	Operating staff	2
1.7	Location of Operating Instructions	2
2	SAFETY RULES	2
2.1	Basic safety precautions	2
2.2	Duties, liability and warranty	3
2.3	Safety symbols	4
2.4	Proper use	5
2.5	Unapproved use	5
2.6	Special owner duties	5
2.7	Staff training	6
2.8	Warning symbols on the working platform	6
2.9	Safety devices	7
2.9.1	Emergency stop switch	7
2.9.2	Fault current circuit breaker	8
2.9.3	Chain break switches	8
2.9.4	Safety switch for outriggers	8
2.10	Safety measures during regular operation	8
2.11	Safety measures during emergency operation	9
2.12	Dangers arising from electricity	9
2.13	Dangers arising from the hydraulic system	9
2.14	When working with electrical equipment on the working platform	10
2.15	When working on electrical installations with the working platform	10
2.16	Fire extinguishing	10
3	PACKAGING AND TRANSPORT	11
3.1	Safety rules	11
3.2	Packaging	11
3.3	Transport	11
3.3.1	Transport with tipper (option)	11
3.3.2	Transport without tipper	12
3.3.2.1	Tipping without tipper	13
4	DESCRIPTION OF THE WORKING PLATFORM	13
4.1	Model overview	13

	Page
4.2	Dimensions and weights 15
4.3	Space requirements at the workplace 16
4.4	Identification of the working platform 17
4.5	Technical data 17
4.6	Equipment 18
4.6.1	Basic equipment 18
4.6.2	Optional equipment 18
5	CONSTRUCTION AND METHOD OF OPERATION 20
5.1	Trolley (base) 20
5.2	Telescopic elements 22
5.3	Power supply system 23
5.3.1	230 VAC operation 23
5.3.2	24 V battery operation 25
5.3.3	Circuit diagram for 230 VAC operation 27
5.3.4	Circuit diagram for 24 V battery operation 28
5.3.5	Battery box 29
5.3.5.1	Battery charger 29
5.3.6	Master control 30
5.4	Electro-hydraulic unit 30
5.4.1	230 VAC operation 30
5.4.2	24 V battery operation 31
5.4.3	Hydraulic schematic 32
5.4.4	Emergency lowering device 33
5.5	Basket 33
6	OPERATION 34
6.1	Safety rules 34
6.2	Initial operation 36
6.3	Basic assembly 36
6.4	Connecting to the power supply 37
6.4.1	230 VAC operation 37
6.4.2	24 V battery operation 37
6.4.3	Connecting to power supply with the 230 V socket 38
6.5	Operation of the working platform 39
6.5.1	Powering up, checking the indicators 39
6.5.2	Selecting the operating position 40
6.5.3	Raising/lowering the working platform 40
6.6	Emergency lowering 41
6.7	Operation of the emergency stop functions 41
6.8	Taking out of operation 41
6.9	Removal and installation of the basket 42
6.9.1	Higher mounting of the one-man basket 43
6.10	Removal and installation of the rotatable basket 43

	Page
6.10.1	Operation of the rotatable basket 43
6.11	Tipper 44
6.11.1	Retrofitting the tipper 44
6.11.2	Operation of the tipper 45
6.12	Operation of the battery charger 46
7	TROUBLESHOOTING AND ELIMINATION OF FAULTS 48
7.1	Safety rules 48
7.2	Troubleshooting 48
7.3	Checking, renewing the fuse 49
7.4	Replacing the battery charger fuse 50
8	MAINTENANCE 50
8.1	Safety rules 51
8.2	Operating personnel qualifications 51
8.3	Cleaning the working platform 52
8.4	Maintenance schedule 53
8.4.1	Check operation of fault current circuit breaker 54
8.4.2	Check oil level in the hydraulic oil tank 55
8.4.3	Check, adjust adjustment of the parking brake 55
8.4.4	Grease outrigger spindles 55
8.4.5	Check batteries (24 V battery operation) 56
8.4.6	Check, clean and spray the Flyer chains 56
8.4.7	Clean breather valve filters 57
8.4.8	Clean and service winch and winch cable 58
8.4.9	Hydraulic system maintenance services 58
8.4.10	Adjust nylon rollers on guides 59
8.5	Lubricants 60
8.6	Inspection booklet 60
8.7	Repair work on the working platform 60
8.8	Spare parts 60
9	ACCIDENT PREVENTION RULES-CHECK 61
10	TAKING OUT OF OPERATION AND STORAGE 61
10.1	Safety rules 61
10.2	Storage conditions 62
10.3	Measures before taking out of operation 62
10.4	Measures during storage 62
10.5	Taking back into operation after storage 62
	Attestation of conformity 63

Alphabetical index

Page

A

Accident prevention rules-check	61
Alternate control	23, 25

B

Basic assembly	36
Basket	33
Higher mounting of the one-man basket	43
Basket, raising/lowering	40
Basket, removal and installation	42
Battery box	29
Battery charger	29
Batteries, checking	56
Breather valve, clean filters	57

C

Chain break switches	8
Chains, check, clean and spray	55
Circuit diagram for 230 VAC operation	27
Circuit diagram for 24 V battery operation	28
Compressed air connector	20
Conformity, attestation of	63
Construction and method of operation	20
Copyrights	2

D

Dangers arising from electricity	9
Dangers arising from the hydraulic system	9
Dimensions and weights	15

E

Electrical system (230 VAC operation)	23
Electrical system (24 V battery operation)	25
Electro-hydraulic unit	30
230 VAC operation	30
24 V battery operation	31
Emergency lowering	41

	Page
Emergency lowering device	33
Emergency stop switch	7
Equipment	18

F

Fault current circuit breaker	8
Fault current circuit breaker, check	54
Fire extinguishing	10
Flyer chains, check, clean and spray	56
Fuse, checking, renewing	50

G

General	1
---------------	---

H

Homologation	1
Hydraulic schematic	32
Hydraulic system, maintenance services	58

I

Identification of the working platform	17
Initial operation	36
Inspection booklet	60
Introduction	1

L

Lubricants	60
------------------	----

M

Maintenance	51
Safety rules	51
Operating personnel qualifications	51
Maintenance schedule	53
Manufacturer	1
Master control	30
Measures before taking out of operation	62

	Page
Measures during storage	62
Model overview	13

N

Nylon rollers, adjust	59
-----------------------------	----

O

Oil level in the hydraulic oil tank, check	55
Operating position, selecting	40
Operating Instructions, date of issue	2
Operating Instructions, issue number	2
Operating Instructions, location	2
Operating staff	2
Operation34	
Safety rules	34
Operation of the battery charger	46
Operation of the emergency stop functions	41
Operation of the rotatable basket	43
Operation of the tipper	45
Operation of the working platform	39
Outriggers	18, 21
Outrigger support	20
Outriggers, grease spindles	55
Owner duties	5

P

Packaging and transport	11
Safety rules	11
Parking brake, check, adjust	55
Personnel	
2	
Powering up	39
Power supply, connecting to	37
Power supply system	23
Proper use	5

O

Qualified personnel	51
---------------------------	----

R

Removal and installation of the rotatable basket	43
Repair work on the working platform	60
Replacing the battery charger fuse	50
Rotatable basket	20

S

Safety devices	7
Safety measures during emergency operation	9
Safety measures during regular operation	8
Safety rules	2
Basic safety precautions	2
Dangers arising from electricity	9
Dangers arising from the hydraulic system	9
Duties, liability and warranty	3
Fire extinguishing	10
Proper use	5
Safety devices	7
Safety measures during emergency operation	9
Safety measures during regular operation	8
Safety symbols	4
Staff training	6
Unapproved use	5
Warning symbols on the working platform	6
When working with electrical equipment on the working platform	10
When working with electrical installations with the working platform	10
Safety switch for outriggers	8
Space requirements at the workplace	16
Spare parts	60
Socket, 230 VAC	23
Staff training	6
Storage conditions when out of operation	62

T

Taking back into operation after storage	62
Taking out of operation	41
Taking out of operation and storage	61
Safety rules	61
Technical data	17
Telescopic elements	22
Telescopic elements, adjust nylon rollers	59
Tipper	19

	Page
Tipper, retrofitting	44
Tipping without tipper	13
Tool tray	19
Transport with tipper (option)	11
Transport without tipper	12
Transport	11
Safety rules	11
Trolley (base)	20
Troubleshooting	48
Troubleshooting and elimination of faults	48
Safety rules	48
Two-person basket	19
Type plates	17

U

Unapproved use	5
----------------------	---

W

Warning symbols on the working platform	6
Weights	15
When working with electrical equipment on the working platform	10
When working on electrical installation with the working platform	10
Winch cable, clean and service	58
Winch, clean and service	58
Working platform, cleaning	52
Working platform, description	13
Working platform, lowering	40

1 GENERAL

1.1 Introduction

These Operating Instructions apply only for Zarges lifts operated with 24 V batteries or 230 VAC and assigned the “homologation” according to section 1.3. In the following text the term “working platform” is used instead of Zarges lift.

The notes on safety and the rules and regulations related to the operation of Zarges working platforms apply to the Zarges working platforms in this documentation.

It is the responsibility of the operator (i.e. owner) to:

- ensure that local, regional and national regulations are observed,
- observe the rules (laws, regulations, guidelines, etc.) in this operating manual for safe operation and servicing,
- ensure that these Operating Instructions are made available to the service staff and that the information, notes and precautions as well as the safety rules are observed in all details.

1.2 Manufacturer

The manufacturer of the working platform described in this documentation is

Firma ZARGES GmbH & Co. KG
Sparte Steigtechnik
P. O. Box 16 30
D-82360 Weilheim

Telephone: 08 81/68 71 00
Telefax: 08 81/68 72 95
E-mail: zarges@zarges.de
Internet: <http://www.zarges.de>

1.3 Homologation

The working platforms mentioned in the following have been tested by



and registered under Test No. M6 99 05 12881 128.

1.4 Issue No. and/or date of issue

The date of issue of the German Operating Instructions is 26th September 2000.

The date of issue of the English Operating Instructions is 13th October 2000.

1.5 Copyrights

- The copyrights for these Operating Instructions remains with the manufacturer.
- Furthermore, all rights are reserved, in particular in the case of granted patent or utility model patents.
- Any violations of these conditions will require compensation.

1.6 Operating staff

According to German regulation VBG 14 only persons 18 years of age, who have been instructed in the use of the working platform and demonstrated their ability to their employer, may be entrusted with the operation of the working platform. The operators must have the written permission of the employer for the operation of the working platform. The order to operate the working platform must be in writing. If several persons are working with the platform, the employer must designate a supervisor.

1.7 Location of Operating Instructions

The Operating Instructions must always be kept on the working platform. If the Operating Instructions have become illegible due to continual use, the employer must order a replacement from the manufacturer.

2 SAFETY RULES

2.1 Basic safety precautions

- The German regulation VBG 14 “Working Platforms” applies for the stability, set-up and use of the aforementioned working platforms.
- The German regulation BGV A2 (formerly VBG 4) “Electrical Installations and Equipment” for the electrical installation applies for the aforementioned working platforms.
- When using the tipper (option), the German regulation BGV D 8 (formerly VBG 8) “Winches, Lifting and Pulling Equipment” applies for the winch.

2.2 Duties, liability and warranty

A basic condition for the safe handling and problem-free operation of the working platforms is a knowledge of the safety precautions and the safety rules. These Operating Instructions, particularly the safety precautions, must be heeded by all persons working with or on the working platform. Furthermore, the accident prevention rules and regulations applying at the work site must be observed.

Dangers involved with the handling of the working platform:

- The working platforms are built according to the state of the art and recognised safety rules. Nevertheless, danger for life and limb of the user and third parties or damage to the working platforms or other properties can occur. The working platforms may only be used

--> for the approved application and

--> in a perfectly safe condition.

Problems which can reduce safety must be remedied immediately.

Warranty and liability

The scope and period of the form of warranty are stated in the sales and delivery conditions. For warranty claims arising from an imperfect documentation, the Operating Instructions valid at the time of delivery (see section 1.4) shall be applicable. The following terms also apply above and beyond the sales and delivery conditions: No liability is assumed for damage to persons and property which has occurred due to one or more of the following reasons:

- non-approved use of the working platforms,
- improper assembly, commissioning, operation and servicing of the working platforms,
- operation of the working platforms with defective safety devices or improperly installed or inoperative safety and protective devices,
- ignorance or non-observation of these Operating Instructions,
- insufficiently qualified or insufficiently instructed operating staff,
- improperly performed repairs,
- use of non-genuine spare parts,
- unapproved modifications on the working platforms,
- insufficient monitoring of machine parts subject to wear,
- catastrophes caused by foreign objects and acts of providence.

It is the responsibility of the operator (owner) to ensure,

- that the safety rules in accordance with section 2 ff. are observed,
- that any unapproved use (see section 2.5), improper installation and unallowed operation are excluded and
- that beyond this the approved use (see section 2.4) is ensured and the working platform is operated according to the contractually agreed operating conditions.

To ensure your warranty, please cut the warranty card (on back cover of these Operating Instructions) out and send it filled in to the manufacturer's address given in section 1.2.

2.3 Safety symbols

The following designations and symbols are used in the Operating Instructions to warn of dangers:



This symbol warns of danger due to dangerously high voltage.



This symbol warns of a danger.



This symbol warns of dangers arising from batteries.



This symbol warns of dangers arising from caustic materials (battery acid).



This symbol warns of explosive materials.



This symbol forbids the use of fire, naked lights and smoking.



This symbol forbids spraying with water.



This symbol indicates tips and instructions for the optimum use of the working platform.



This symbol indicates tips for proper disposal and storage of waste materials.

2.4 Proper use

The working platforms described in these Operating Instructions may only be used in conjunction with four outriggers and basket as working platform for transporting persons, tools and materials. The maximum load capacity may not be exceeded.

Proper use also includes:

- observing all the notes in these Operating Instructions and
- performing the services and the safety checks on schedule.

2.5 Unapproved use

Improper use - a deviation from the information given on the working platforms documented in section 2.4 of these Operating Instructions - is defined as **unapproved use** in the sense of product liability legislation (Issue 1st Aug. 1997). This also includes disregard of the standards and guidelines cited in these Operating Instructions.

Dangers can occur during improper use. Such improper applications are e. g.:

- using the working platform as a fork lift truck,
- using the working platform to press plates against ceilings.

2.6 Special owner duties

Each owner must lay down operating instructions for the use of working platforms and to make them available to the operators. These instructions must contain organisational measures based on valid regulations (accident prevention rules, trade association rules, etc.) and on these Operating Instructions.

2.7 Staff training

Only trained and instructed personnel may work with or on the working platform.

The employer must clearly establish the responsibilities of personnel for operation, servicing, repair and the safety inspection.

Persons Activity	Instructed Persons	Persons with Technical Training	Electrician	Expert	Supervisor with Appropriate Competence
Commissioning, Operation, Decommissioning	X	X	X	X	X
Troubleshooting		X	X	X	
Mechanical Troubleshooting		X			
Electrical Troubleshooting			X		
Maintenance	X	X	X		X
Repair		X	X		X
Safety inspection				X	
Storage	X	X			

Personnel being instructed may only work with or on the working platform under the supervision of an experienced operator.

Only instructed personnel is allowed to operate the controls in the switch box or on the telescopic element.

The instruction should be recorded in writing and the record signed.

2.8 Warning symbols on the working platform

All safety and danger notices (self-adhesive labels, painted areas) on the working platform must be kept in a legible condition and renewed, if necessary.

2.9 Safety devices

Before taking the working platform into operation, make sure that all protective devices are mounted properly and in working order. Any manipulation of the protective devices, for example jumping the outrigger limit switch, is forbidden.

Protective devices may only be removed after

- the working platform has come to a standstill and is turned off,
- securing against inadvertent switching-on (switch box closed and key removed).

For the installation of accessories the protective devices must be installed as specified.

2.9.1 Emergency stop switch

The emergency stop switch (1/1) at the switch box interrupts the functional elements of the working platform. It protects against dangers due to inadvertent or unauthorised operation of the working platform.

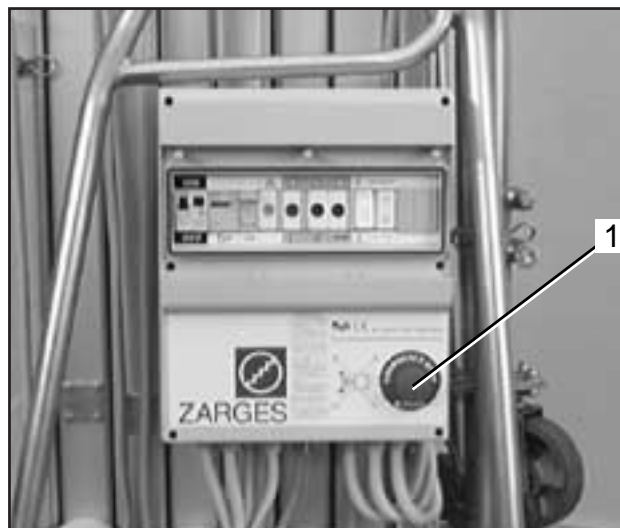

Fig. 1 Emergency stop switch at switch box

When the emergency stop switch is pressed, the red STOP warning light (2/2) illuminates at the alternate control.

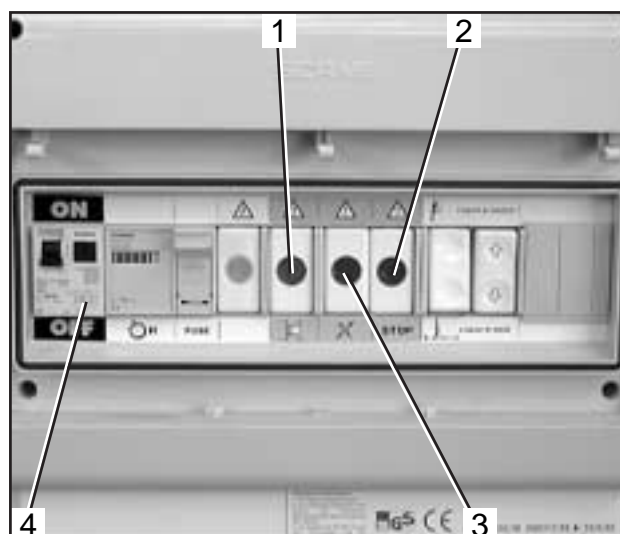

Fig. 2 STOP warning light

The emergency stop switch (3/2) at the master control (on the telescopic element) cuts out the functional elements of the working platform. It protects against dangers due to inadvertent or unauthorised operation of the working platform.

The operation of the emergency stop switch is indicated by the **extinguishing** of the green indicator light “emergency stop on the master control/outtrigger not fully depressed” (2/1) on the alternate control. The red STOP warning light (2/2) on the alternate control **is not illuminated**.

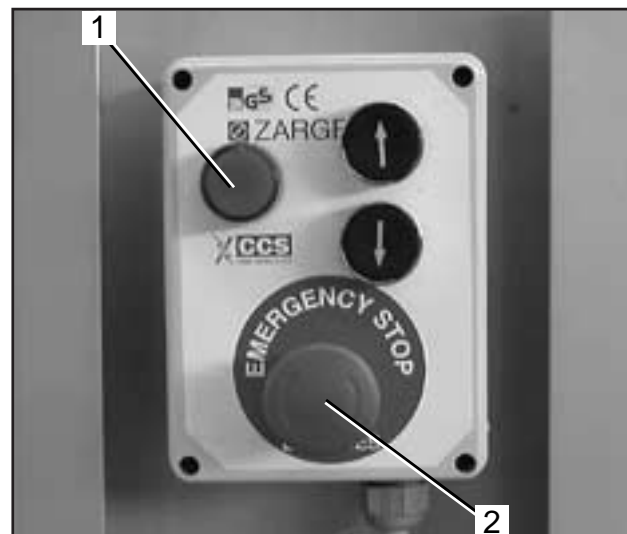

Fig. 3 Emergency stop switch at master control

2.9.2 Fault current circuit breaker

The fault current circuit breaker (2/4) protects the operator against dangerously high contact voltages. When a fault current of 30 mA and higher occurs, the fault current circuit breaker is triggered automatically. This disconnects all poles of the power supply behind the fault current circuit breaker. On the 24 V battery-operated working platform the fault current circuit breaker is only used to protect the 230 V socket on the telescopic element.

2.9.3 Chain break switches

The telescopic elements are provided with chain break switches. When a chain breaks or is slack, the electronics in the switch box detect this fault. As a result, the chain inspection light (2/3 and 3/1) on the alternate control and on the master control.

2.9.4 Safety switch for outriggers

The receivers for the outriggers are each provided with a safety switch. When the outriggers are retracted, the switch is operated. When all four outriggers are retracted, the green ready light (2/1) on the switch box illuminates if the emergency stop switch at the master control is not on.

2.10 Safety measures during regular operation

The working platform may only be operated if all protective devices are fully operational.

Before switching on or extending the working platform, make sure that no-one can be put at risk by this action.

Before taking the working platform into operation, inspect it for external visible damage and the safety devices (e. g. emergency stop switch) for proper operation.

During operation of the working platform the switch box must be closed and the key removed.

2.11 Safety measures during emergency operation

The emergency lowering device may only be used when the electrical installation for lowering the basket has failed.

The employer must instruct the operator in how to operate the emergency lowering function.

Emergency lowering may only be carried out when the operator and the helper are in eye and voice contact. Both persons must be located such that any risk arising from the lowering procedure is precluded.

The knurled nut on the emergency lowering valve may only be opened very slowly in order to prevent the basket from lowering too fast.

2.12 Dangers arising from electricity

Only a qualified electrician may work on and open the electrical installation.

The electrical installation of the working platform must be inspected regularly. Loose connections and damaged cables must be renewed before taking the working platform into operation.

For services and repairs the power supply to the working platform must be disconnected.

2.13 Dangers arising from the hydraulic system

When hydraulic oil gets into the eyes, flush them immediately with clear water and then seek immediate medical attention.

Do not allow hydraulic oil to come into contact with skin or clothing. If hydraulic oil has contacted the skin nevertheless, immediately wash the skin thoroughly and repeatedly with water and soap; if not, there is a risk of skin damage.

Clothing dirtied or soaked with hydraulic oil must be taken off immediately.

Ensure that persons who have inhaled hydraulic oil vapours (fog) get medical attention immediately.

When leaks have occurred in the hydraulic system, do not operate the working platform and/or stop operation immediately.

Bind leaked hydraulic oil immediately with an oil binding agent. The contaminated oil binding agent must only be stored in suitable containers and disposed of in accordance with local legislation.

2.14 When working with electrical equipment on the working platform

The working platform is equipped with a 230 VAC socket, it can be used for work with electrical equipment.

Observe the following precautions when the electrical equipment is operated with a different power supply (e. g. extension cable).

When working with electrical equipment while standing in the basket, follow regulation BGI 594 (formerly ZH 1/228).

Particularly important is:



Electrical equipment may only be operated with a protective voltage (48 V), with protective isolation (isolating transformer) or, if connected to a fault current ≤ 30 mA, with a fault current circuit breaker.

2.15 When working on electrical installations with the working platform

Work on or in the vicinity of unprotected live installations may not be carried out with the working platform if

- the installation has not been shut off,
- the installation has not been secured against switching on again,
- voltage has been detected in the installation,
- the installation has not been grounded with an earthing bar and
- the installation has not been safeguarded against adjacent electrically live parts.

2.16 Fire extinguishing

Use a CO₂ fire extinguisher to extinguish fires in the electrical or hydraulic system.

3 PACKAGING AND TRANSPORT

The working platform can easily be moved with the wheels mounted on the trolley (base).

3.1 Safety rules

The working platform may only be moved in the lowered state.

After moving the platform to the new site, brake the wheels immediately.

Tipping the working platform without a tipper (option) requires utmost caution as the working platform must be held by hand after it has passed the tip-over point.

At least three persons are required to tip the working platform without a tipper.

When transporting the platform on a car trailer, the trailer must have a capacity appropriate for the working platform. The working platform should be put on the trailer in such a way that the supporting load of the towing vehicle is not exceeded. Lash the working platform on the trailer with adjustable belts.

When transporting a working platform operated with 24 V batteries, remove the battery box before tipping the working platform.

3.2 Packaging

No special packaging is required to transport the working platform. If the equipment is transported during rain or snow, protect the electrical system with tarpaulin placed of the working platform.

3.3 Transport

3.3.1 Transport with tipper (option)

- Tip the working platform with the tipper (option) (refer to section 6.11).
- Move the working platform in front of the trailer so that it can be pulled on the trailer with the winch.
- Place a ramp made of a suitable material against the trailer.
- Remove the shackle on the trolley (4/2).
- Remove the pulley (4/3) on the tipper and take off the winch cable. Refit the pulley.



Fig. 4 Winch



The winch cable must always be kept taut in order to prevent the cable windings on the winch drum from going apart.

- Attach the winch cable to the trailer at a suitable spot.
- Turn the crank (4/1) on the winch cable to pull the working platform onto the trailer.
- Operate the parking brake (5/1) and tie the working platform to the trailer with adjustable straps.
- To unload the working platform from the trailer, release the parking brake and pull the working platform from trailer with the winch cable.

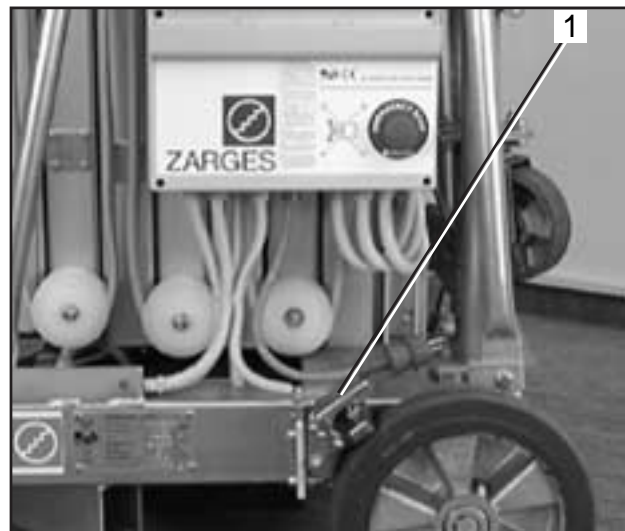

Fig. 5 Parking brake



The winch cable must always be kept taut to ensure that the cable is wound onto the drum uniformly.

- Tilt the working platform to the vertical position with the tipper; refer to section 6.11.

3.3.2 Transport without tipper

The working platform without the tipper should only be moved in of the vertical position.

- Position the working platform in front of the trailer so that it can be pulled onto the trailer with the winch.
- Place a ramp made of a suitable material against the trailer.
- Pull the working platform onto the trailer with the winch.
- Apply the parking brake (5/1) and lash the working platform to the trailer with adjustable straps.



If the working platform is to be loaded onto the trailer by hand, at least four persons are required and utmost caution should be exercised to prevent injuries in case the working platform rolls.

3.3.2.1 *Tipping without tipper*

- Insert an outrigger approx. 0.4 m into each mounting hole (5.1/1).
- Lift the working platform at the inserted outriggers with two persons. A third person must secure the platform at the rear when the tipping point is reached.



The inserted outriggers may not be used to level the working platform.

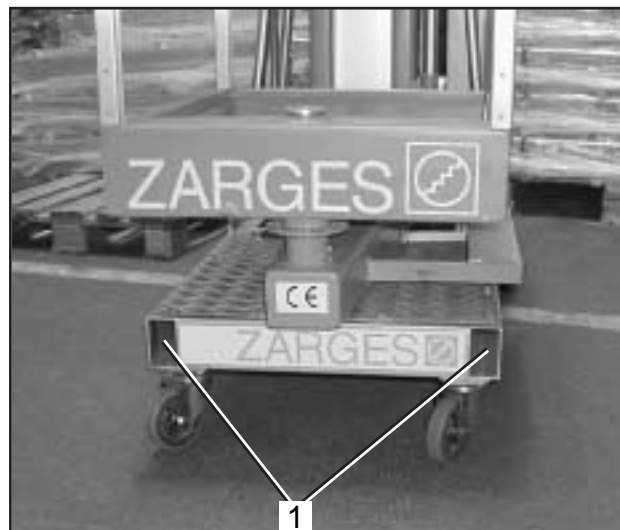

Fig. 5.1 Mounting holes

4 DESCRIPTION OF THE WORKING PLATFORM

4.1 Model overview

The working platform is available in four different heights. All heights are available either as 230 V AC or as 24 V battery models.

Working platforms which are used for working outside require outriggers with a greater length.



The use of platforms for working outside with outriggers for working inside is forbidden.

The basic version of the working platform has a basket for one person (capacity 120 kg). A basket for two persons (capacity 200 kg) and a rotatable basket (capacity 120 kg) are available as option. When the basket for two persons or the rotatable basket is used, outriggers with a greater length are required.



Working platforms with a basket for two persons may be used inside only with outriggers 40184, 40185 and outside only with outriggers 40186 and 40188.

Working platforms with a rotatable basket may be used inside only with outriggers 40185, 40186 and 40187. They may not be used for working outside.

The outriggers which can be used with the working platform are stamped on the type plate on the trolley; refer to section 4.4.

The following table shows the possible working platform combinations.

Order No.	Platform Height	Basket Size Max. Capacity	Order No. Inside Use Outrigger	Order No. Outside Use Outrigger
Operation with 24 V Battery				
40163 B	5.80 m	Basket for 1 person, 120 kg	40182	40186
40163 B	5.80 m	Basket for 2 persons, 200 kg	40184	40186
40163 B	5.80 m	Rotatable basket, 120 kg	40185	--
40164 B	8.00 m	Basket for 1 person, 120 kg	40182	40186
40164 B	8.00 m	Basket for 2 persons, 200 kg	40184	40186
40164 B	8.00 m	Rotatable basket, 120 kg	40185	--
40165 B	10.00 m	Basket for 1 person, 120 kg	40183	40187
40165 B	10.00 m	Basket for 2 persons, 200 kg	40185	40188
40165 B	10.00 m	Rotatable basket, 120 kg	40186	--
40166 B	12.00 m	Basket for one person, 120 kg	40183	40187
40166 B	12.00 m	Basket for 2 persons, 200 kg	40185	40188
40166 B	12.00 m	Rotatable basket, 120 kg	40187	--
Operation with 230 VAC				
40167 ST	5.80 m	Basket for one person, 120 kg	40182	40186
40167 ST	5.80 m	Basket for 2 persons, 200 kg	40184	40186
40167 ST	5.80 m	Rotatable basket, 120 kg	40185	--
40168 ST	8.00 m	Basket for 1 person, 120 kg	40182	40186
40168 ST	8.00 m	Basket for 2 persons, 200 kg	40184	40186
40168 ST	8.00 m	Rotatable basket, 120 kg	40185	--
40169 ST	10.00 m	Basket for 1 person, 120 kg	40183	40187
40169 ST	10.00 m	Basket for 2 persons, 200 kg	40185	40188
40169 ST	10.00 m	Rotatable basket, 120 kg	40186	--
40170 ST	12.00 m	Basket for 1 person, 120 kg	40183	40187
40170 ST	12.00 m	Basket for 2 persons, 200 kg	40185	40188
40170 ST	12.00 m	Rotatable basket, 120 kg	40187	--

4.2 Dimensions and weights

Figure 6 shows the dimensions and weights of the working platform in connection with the following table.

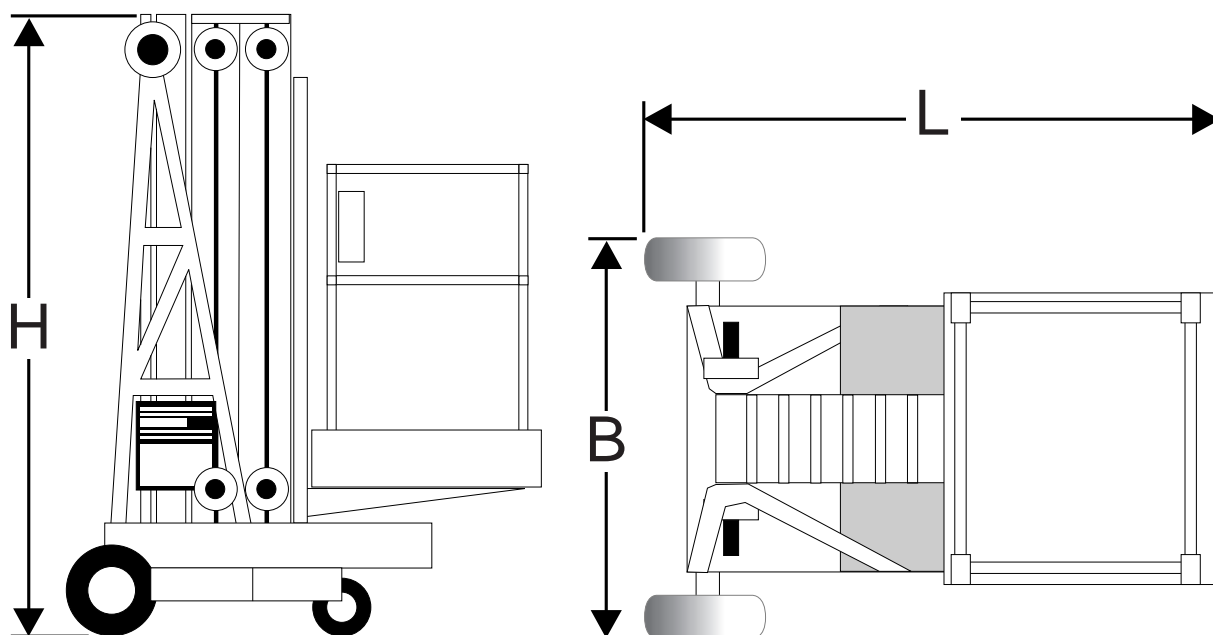

Fig. 6 Dimensions

Order No.	40163 B	40164 B	40165 B	40166 B	40167 ST	40168 ST	40169 ST	40170 ST
Length [L]	1.38 m	1.38 m	1.38 m	1.38 m	1.38 m	1.38 m	1.38 m	1.38 m
Width [B]	0.81 m	0.81 m	0.81 m	0.81 m	0.81 m	0.81 m	0.81 m	0.81 m
Height [H]	1.98 m	1.98 m	2.51 m	2.96 m	1.98 m	1.98 m	2.51 m	2.96 m
Weight without batteries	310 kg	360 kg	420 kg	480 kg	310 kg	360 kg	420 kg	480 kg
Weight with batteries	383 kg	433 kg	493 kg	553 kg	--	--	--	--

The dimensions given in the table refer to the working platform without outriggers. The dimensions with outriggers are shown in section 4.3.

4.3 Space requirements at the workplace

Figure 7 shows the place requirement of the working platform at the workplace.

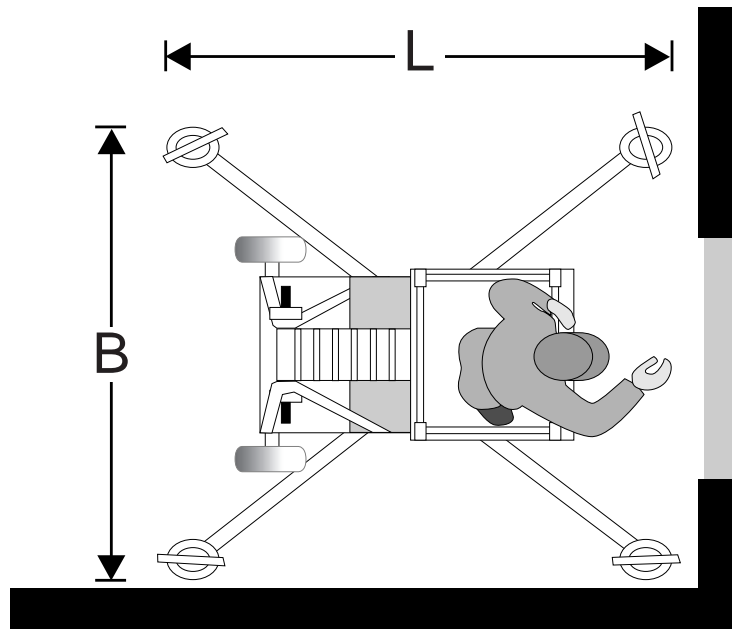

Fig. 7 Size of workplace

Order No.	40163 B	40164 B	40165 B	40166 B	40167 ST	40168 ST	40169 ST	40170 ST
Inside use with one-person basket								
Length [L]	1.36 m	1.36 m	1.50 m	1.50 m	1.36 m	1.36 m	1.50 m	1.50 m
Width [B]	1.36 m	1.36 m	1.50 m	1.50 m	1.36 m	1.36 m	1.50 m	1.50 m
Outside use with one-person basket								
Length [L]	2.55 m	2.55 m	3.00 m	3.00 m	2.55 m	2.55 m	3.00 m	3.00 m
Width [B]	2.55 m	2.55 m	3.00 m	3.00 m	2.55 m	2.55 m	3.00 m	3.00 m
Inside use with two-person basket								
Length [L]	1.72 m	1.72 m	2.10 m	2.10 m	1.72 m	1.72 m	2.10 m	2.10 m
Width [B]	1.72 m	1.72 m	2.10 m	2.10 m	1.72 m	1.72 m	2.10 m	2.10 m
Outside use with two-person basket								
Length [L]	2.55 m	2.55 m	5.00 m	5.00 m	2.55 m	2.55 m	5.00 m	5.00 m
Width [B]	2.55 m	2.55 m	5.00 m	5.00 m	2.55 m	2.55 m	5.00 m	5.00 m
Inside use with rotatable basket (outside use is not allowed)								
Length [L]	2.1 m	2.1 m	2.55 m	3.00 m	2.1 m	2.1 m	2.55 m	3.00 m
Width [B]	2.1 m	2.1 m	2.55 m	3.00 m	2.1 m	2.1 m	2.55 m	3.00 m

4.4 Identification of the working platform

The type plate (8) of the working platform is located on the frame of the trolley. It contains information according to VBG 14.

The number of the outriggers for the working platform is stamped in the field "STABILISATOREN NR.". .



Fig. 8 Working platform type plate

The outrigger type plate (9) is affixed on the side. The data are stamped into the cut-out areas.

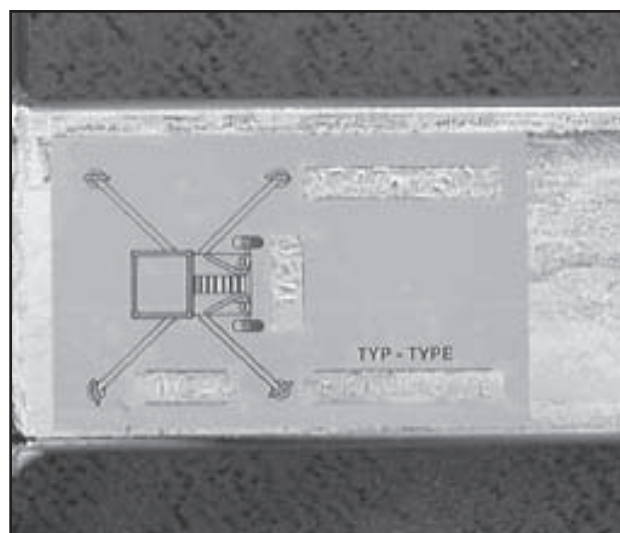

Fig. 9 Outrigger type plate

4.5 Technical data

Electrical system (operation with 230 VAC)

Power supply	230 VAC, 50 Hz
Protection of feed line	Line circuit breaker 16 A, Type "C"
Feed line	Minimum gauge up to 40 m 3 x 2.5 mm ² Type H07RN-F
	Minimum gauge 40 m - 80 m 3 x 4 mm ² Type H07RN-F
Fault current circuit breaker	230 VAC, 16 A, I _{AN} 0.03 A
Protection in switch box	500 V, 2 A

Operation with 24 V batteries

Power supply	24 VDC from 2 batteries
Battery	Rated voltage 12 V Rated capacity 100 Ah Cold test current 480 A
Weight of battery box	73 kg
Fault current circuit breaker, for socket	230 V, 16 A, I_{AN} 0.03 A
Protection in switch box	500 V, 2 A
Battery charger	
- Power supply	230 VAC, 50 Hz
- Rated charging voltage	24 V
- Max. charging current	22 A
- Trickle charging current	0.5 A

Hydraulic system

Tank capacity	11 litres
Operating pressure	100 bar

4.6 Equipment

4.6.1 Basic equipment

The basic equipment of the working platform includes:

- one-person basket, load capacity 120 kg, mounting ladder
- battery box with charger (operation with 24 V batteries)
- four outriggers, their size being dependent on the type of working platform
- socket, 230 VAC
- Operating Instructions

4.6.2 Optional equipment

A variety of optional equipment is available for the working platform. The option can be ordered from ZARGES GmbH & Co. KG any time.

Outriggers

When planning to change the use of the working platform from inside to outside use, the outriggers required for your working platform can be ordered from the manufacturer. Please state the exact type of your working platform in your order.

Tipper

The tipper, Order No. 40172, (10) allows the working platform to be moved by only one person. A helper is only required to tip the platform to the transport position and back. The working platform can also be moved through low doors.



Fig. 10 Tipper

Tool tray

Due to its depth, the tool tray, Order No. 40176, (11/1) is a safe place to deposit any tools used in the basket. It is easily fastened with two screws.

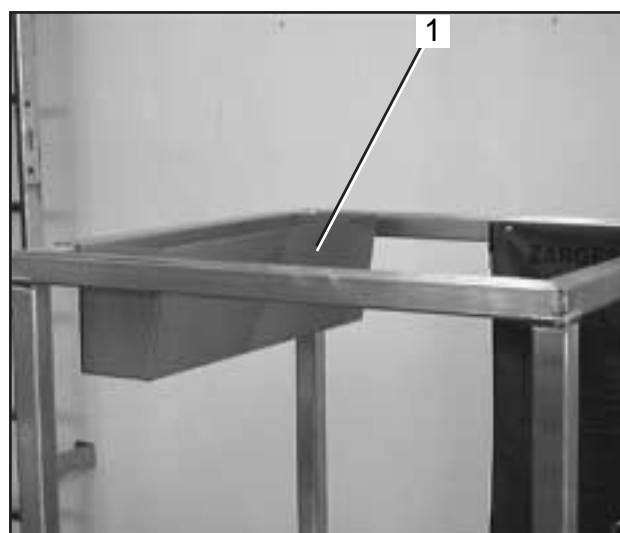

Fig. 11 Tool tray

Basket for two persons

Using the basket for two persons (12), Order No. 40179, increases the load capacity to 200 kg. Depending on the type of working platform, other outriggers may be required.



The use of the basket for two persons with outriggers for the basket for one person is forbidden.



Fig. 12 Basket for two persons

Basket for one person with swivel

The use of the basket for one person with a swivel (13), Order No. 40177, (load capacity 120 kg) extends the reach range of the working persons noticeably. The basket can be swivelled 360° and can be locked in position every 45°. The rotary knob for the detent (13/1) is mounted on the telescopic element for easy access. The outriggers do not need to be changed.



Fig. 13 Basket for one person with swivel

Compressed air connector

For work with pneumatic tools, the working platform can be equipped or retrofitted with a compressed air connector, Order No. 40174, on the telescopic arm. The compressed air connector is designed for an operating pressure of 6 bar.

Outrigger support

The outrigger support, Order No. 40178 or 40194, is part of the optional equipment and is used for storing and transporting the outriggers.

5 CONSTRUCTION AND METHOD OF OPERATION

The section Construction and Method of Operation contains the description of the various assemblies and components.

5.1 Trolley (base)

The working platform assemblies are mounted on the trolley (base). The trolley is made of galvanised shaped steel.

The trolley (14/3) has four mounting holes for the outriggers (14/2). When the outriggers (14/6) are pushed in as far as the mechanical stop, the appropriate safety switch is actuated. The working platform can only be operated after all four outriggers have been installed.

For easier tipping of the working platform, an outrigger can be inserted into each mounting hole (14/4).

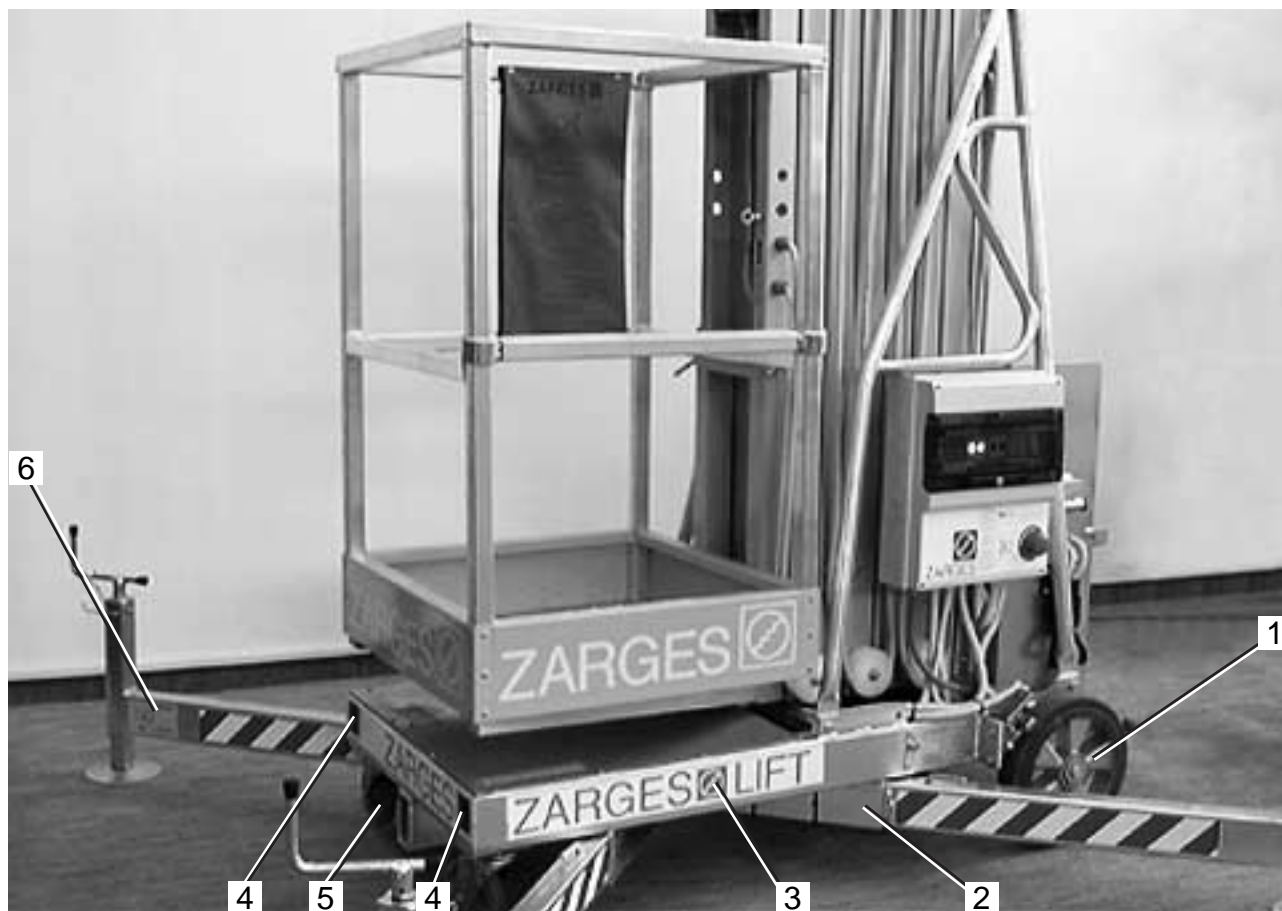

Fig. 14 Trolley

- | | | | |
|---|-------------------------|---|-------------------------------------|
| 1 | Wheel | 4 | Outrigger mounting hole for tipping |
| 2 | Outrigger mounting hole | 5 | Castor |
| 3 | Trolley (base) | 6 | Outrigger |

For easier tipping of the working platform, an outrigger can be inserted into each mounting hole (14/4).

The outriggers are equipped with spindles which are used for the alignment of the working platform. After the alignment with the spindles secure the cranks with the retaining pins.

The wheels (14/1) and castors (14/5) allow easy movement of the working platform.



The working platform may only be moved when lowered.

The parking brakes mounted on the wheels (14/1) allow the working platform to be braked.

5.2 Telescopic elements

The telescopic elements are made of extruded aluminium shapes. They run on adjustable nylon rollers.

The first telescopic element (15/4) is fixed to the trolley frame. The second telescopic element (15/2) is extended with a hydraulic cylinder (15/3). The third (15/1) to fifth elements are pulled up with Flyer chains. All the telescopic elements telescope equally.

The hydraulic cylinder is supplied with boost pressure by the electro-hydraulic unit (refer to section 5.4).

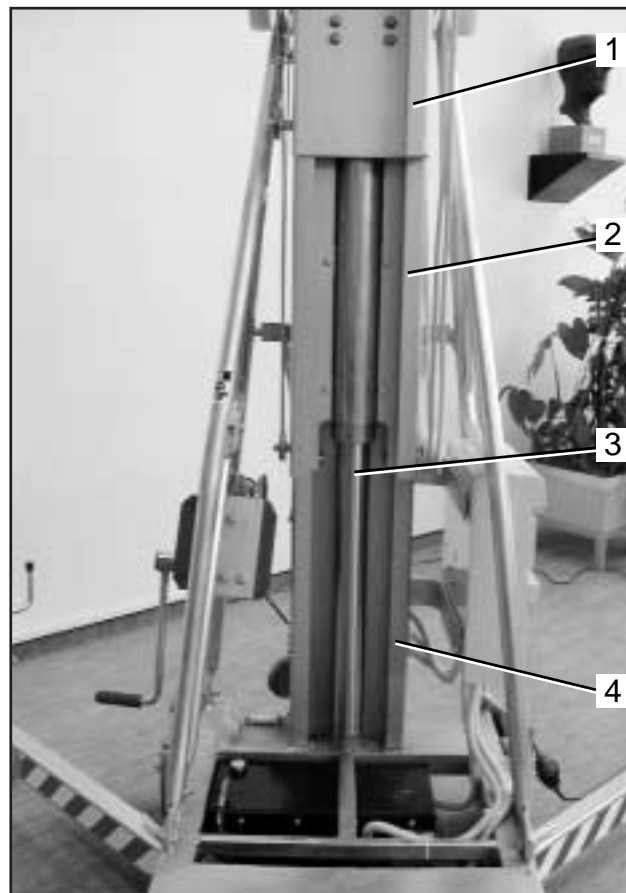

Fig. 15 Telescopic elements

The Flyer chains (16/1) are installed in each telescopic element as pairs and they are guided on rollers.

In the telescopic elements the Flyer chains are routed past chain break switches at the master and alternate control which cause the chain inspection light to illuminate in case of chain elongation or a chain break.

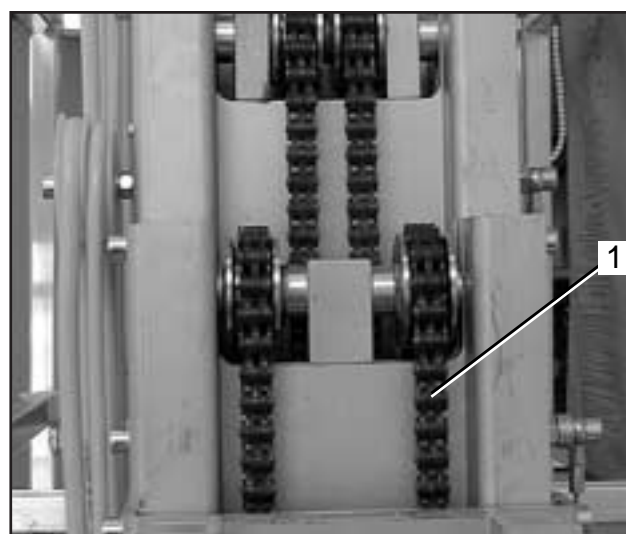

Fig. 16 Flyer chains

5.3 Power supply system

5.3.1 230 VAC socket

For work with electrical equipment in the basket, the working platform can be equipped with a 230 VAC socket, order No. 40173, (17/1). Safeguarding is via the fault current circuit breaker installed in the switch box. The maximum power consumption of the load must not exceed 2500 W.

When the working platform is operated with 24 V batteries, connect an extension cable with a gauge appropriate for the load to the connector on the switch box.

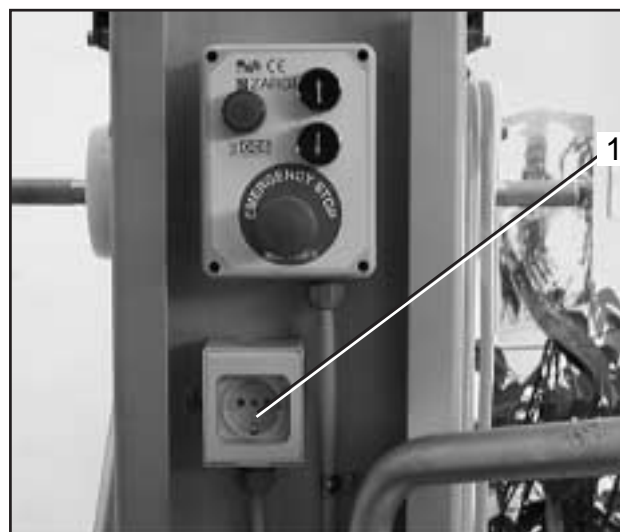

Fig. 17 Switch box

5.3.1 230 VAC operation

The central element of the electrical system is the switch box (18), which contains the necessary components for controlling and securing the working platform. The switch box contains the alternate control with all the functional elements. Also located on the switch box is one of the two emergency stop switches (18/2).

The alternate control is covered with a plastic cover (18/1) and secured against unauthorised use with a lock.

The 0.5 m long connecting cable is led out of the switch box.



Bild 18 Switch box

Alternate control

The fault current circuit breaker (19/1) protects the operator against shock hazard voltages. If a fault current of 30 mA and more occurs, the fault current circuit breaker triggers automatically so that the power supply behind the fault current circuit breaker is disconnected at all poles. On this model the fault current circuit breaker serves as master switch for turning on the electrical system. The equipment is turned on by switching the fault current circuit breaker to "ON". The trigger function of the fault current circuit breaker can be checked by pressing the test button (19/10). For the test, the fault current circuit breaker must be in the "ON" position; when the test button is pressed, it must return to the "OFF" position.

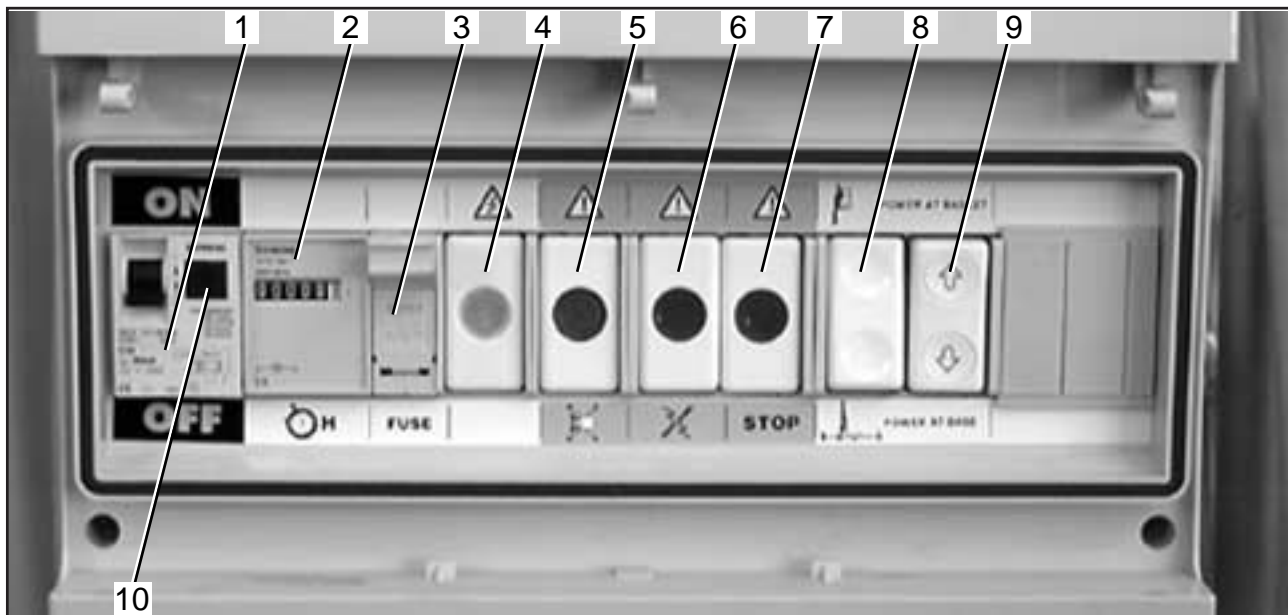

Fig. 19 Alternate control

- | | | | |
|---|--|----|---------------------------------|
| 1 | Fault current circuit breaker | 6 | Chain inspection light |
| 2 | Hour meter | 7 | STOP warning light |
| 3 | Fuse 500 V, 2 A | 8 | Master/alternate control switch |
| 4 | Ready light | 9 | Basket up/down switch |
| 5 | Indicator light "Emergency stop at the master control/outriggers not fully inserted" | 10 | Test button |

The hour meter (19/2) measures and indicates the service hours of the working platform.

The 500 V, 2 A fuse (19/3) protects the electrical system, which is designed for 2 A, against overcurrents.

The orange ready light (19/4) is illuminated after all the outriggers are fully inserted, the fault current circuit breaker is switched to the "ON" position and both emergency stop switches are pulled out. The basket can not be raised if the ready light is not illuminated.

If the green indicator light "Emergency stop at the master control/outriggers not fully inserted" (19/5) does not light after the operation of the fault current circuit breaker, at least one of the four outriggers is not fully inserted or the emergency stop switch at the master control is depressed.

The red chain inspection light (19/6) illuminates if one of the Flyer chains has broken during operation or is stretched.

The red STOP warning light (19/7) is illuminated if the emergency stop switch at the switch box was operated.

The operation of the function basket up/down with either the master or alternate control can be preselected by pressing the master/alternate control switch (19/8). Pressing the toggle switch at the top preselects operation with the master control, pressing it down preselects operation with the alternate control.

If operation with the alternate control was preselected, the basket can be raised or lowered with the basket up/down switch.

5.3.2 24 V battery operation

The central element of the electrical system is the switch box (20), which contains the necessary components for controlling and securing the working platform. The switch box contains the alternate control with all the functional elements. Also located on the switch box is one of the two emergency stop switches (20/2).

The alternate control is covered with a plastic cover (20/1) and secured against unauthorised use with a lock.

The switch box is powered via a connector to the battery box, refer to section 5.3.5.



Fig. 20 Switch box

Alternate control

The fault current circuit breaker (21/1) protects the operator against shock hazard voltage. If a fault current of 30 mA and more occurs, the fault current circuit breaker triggers automatically so that the power supply behind the fault current circuit breaker is disconnected at all poles. When the fault current circuit breaker is toggled up, the 230 V socket on the telescopic element is supplied with power.

The trigger function of the fault current circuit breaker can be checked by pressing the test button (21/11). For the test, the fault current circuit breaker must be in the "ON" position; when the test button is pressed, it must return to the "OFF" position.

The hour meter (21/2) measures and indicates the service hours of the working platform.

The 500 V, 2 A fuse (21/3) protects the electrical system, which is designed for 2 A, against overcurrents.

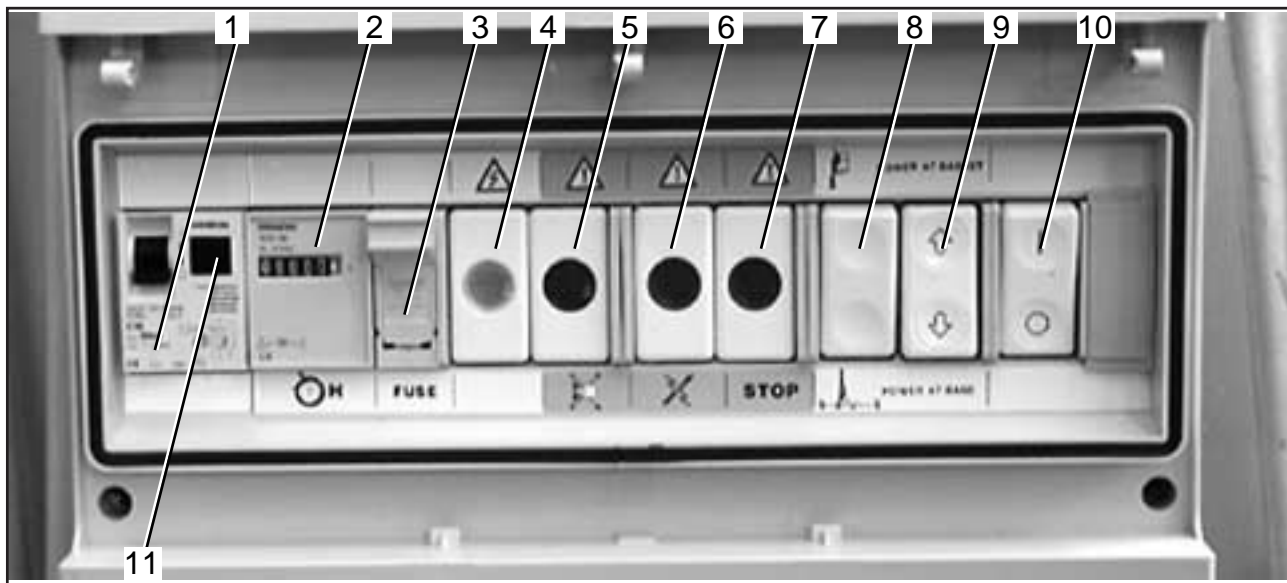

Fig. 21 Alternate control

- | | | | |
|---|--|----|---------------------------------|
| 1 | Fault current circuit breaker | 6 | Chain inspection light |
| 2 | Hour meter | 7 | STOP warning light |
| 3 | Fuse 500 V 2 A | 8 | Master/alternate control switch |
| 4 | Ready light | 9 | Basket up/down switch |
| 5 | Indicator light "Emergency stop at the master control/outriggers not fully inserted" | 10 | Master switch |
| | | 11 | Test button |

The orange ready light (21/4) is illuminated when all the outriggers are fully inserted, the fault current circuit breaker is set to the ON position and both emergency stop switches are pulled out. The basket can not be raised if the ready light not is illuminated.

If the green indicator light "Emergency stop at the master control/outriggers not fully inserted" (21/5) is not illuminated, after the operation of the master switch (21/10) at least one the four outriggers is not fully inserted or the emergency stop switch at the master control is depressed.

The red chain inspection light (21/6) is illuminated if one of the Flyer chains had broken during operation or is stretched.

The red STOP warning light (21/7) is illuminated if the emergency stop switch on the switch box was depressed.

The operation of the function basket up/down with either the master or alternate control can be preselected by depressing the master/alternate control switch (21/8). Depressing the toggle switch at the top preselects operation with the master control, depressing it at the bottom preselects operation with the alternate control.

If operation with the alternate control was preselected, the basket can be raised or lowered with the basket up/down switch (21/9).

Press the master switch (21/10) to position "I" for powering up.

5.3.3 Circuit diagram for 230 VAC operation

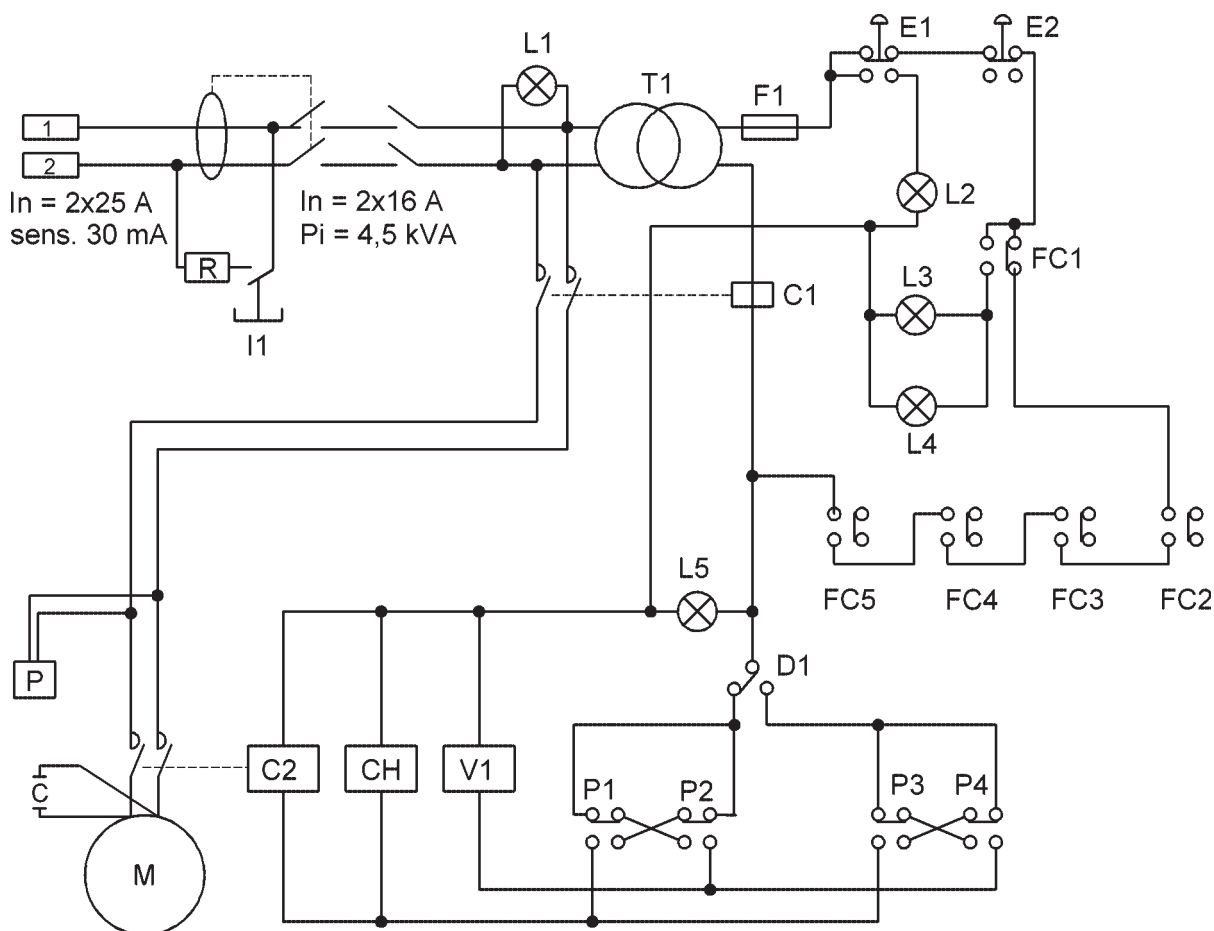

I1	Fault current circuit breaker	L5	Indicator light "Emergency stoplight at master control/out-rigger not fully inserted"
D1	Master/alternate control switch	E1	Emergency stop (master control)
P1/P2	Basket up/down switch (master control)	E2	Emergency stop (alternate control)
P3/P4	Basket up/down switch (alternate control)	C1	Main relay
F1	Fuse 500 V 2 A	C2	Motor relay
F2	Fuse 100 A	M	Electric motor
FC1	Chain break switch	CH	Hour meter
FC2-FC5	Outrigger safety switch	V1	Lowering stop valve
L1	Ready light	C	Capacitor 60 mF
L2	STOP warning light	P	230 VAC socket
L3	Chain inspection light (master control)		
L4	Chain inspection light (alternate control)		

5.3.4 Circuit diagram for 24 V battery operation

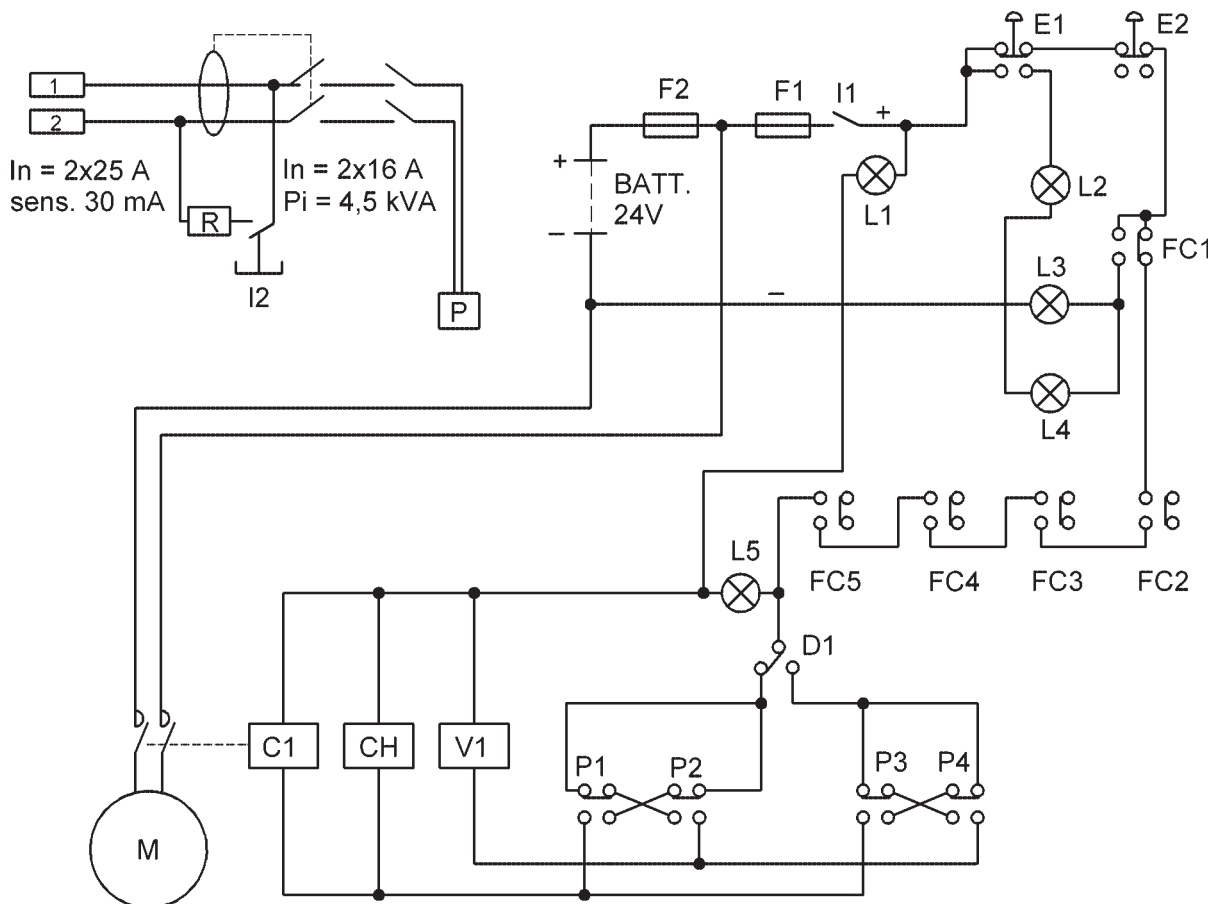

I1	Master switch	L5	Indicator light "Emergency stoplight at master control/out-rigger not fully inserted"
I2	Fault current circuit breaker	E1	Emergency stop (master control)
D1	Master/alternate control switch	E2	Emergency stop (alternate control)
P1/P2	Basket up/down switch (master control)	C1	Main relay
P3/P4	Basket up/down switch (alternate control)	C2	Motor relay
F1	Fuse 500 V 2 A	M	Electric motor
F2	Fuse 100 A	CH	Hour meter
FC1	Chain break switch	V1	Lowering stop valve
FC2-FC5	Outrigger safety switch	C	Capacitor 60 mF
L1	Ready light	P	230 VAC socket
L2	STOP warning light		
L3	Chain inspection light (master control)		
L4	Chain inspection light (alternate control)		

5.3.5 Battery box

The batteries (22/3) required for the power supply and the battery charger (22/2) are located in the battery box (22/1).

The battery box is hooked into the first telescopic element attached to the trolley. If the working platform is equipped with a tipper, the battery box must be placed beside the working platform.

The two 12 V batteries are connected in series so that the operating voltage is 24 V. The batteries are practically maintenance-free so that battery water needs to be replenished only very seldom.

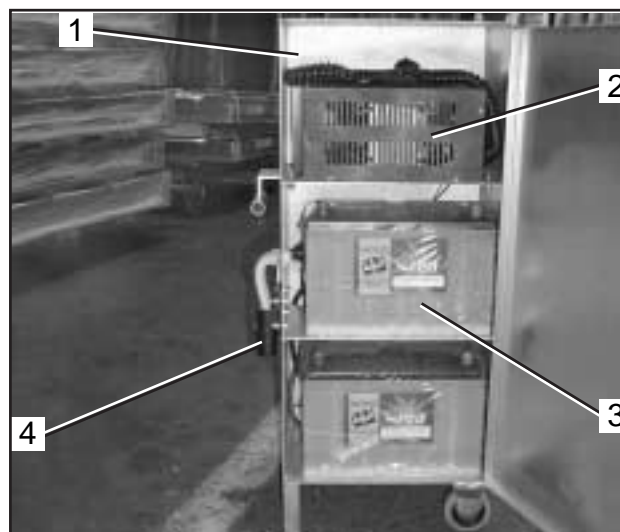

Fig. 22 Battery box

The electrical system of the working platform is connected with the connector (22/4) to the battery box. The plug is protected against false polarity.

5.3.5.1 Battery charger

The batteries can be charged with the battery charger (23/2), the batteries are connected directly to the battery charger. The battery charger is designed for easy operation, i. e. only a few steps are required to charge the battery. After connection, the battery charger controls charging automatically.

The battery charger is supplied with 230 VAC via the connecting cable (23/1). The connecting cable plug is also stowed in the battery box. The battery charger is protected by a fast-acting 4 A fuse (23/3) installed in the unit.

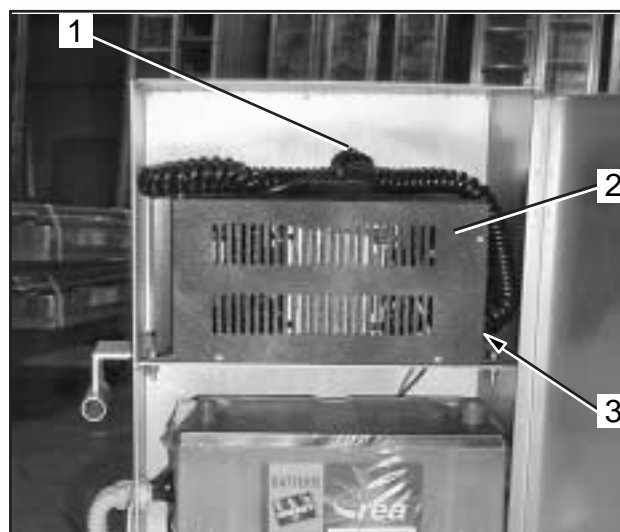

Fig. 23 Battery charger

After connection to the mains power supply, the charger regulates the charging current in the range of 0.5 to 12 A automatically.

A charging indicator (23/1) is located at the top of the battery charger to indicate the various phases of the charging procedure.

If the GREEN LED (23.1/3) illuminates, the automatic charging procedure is finished.

If the YELLOW LED (23.1/2) illuminates, the charging procedure is in the final phase.

If the RED LED (23.1/1) illuminates, the charging procedure has just started.

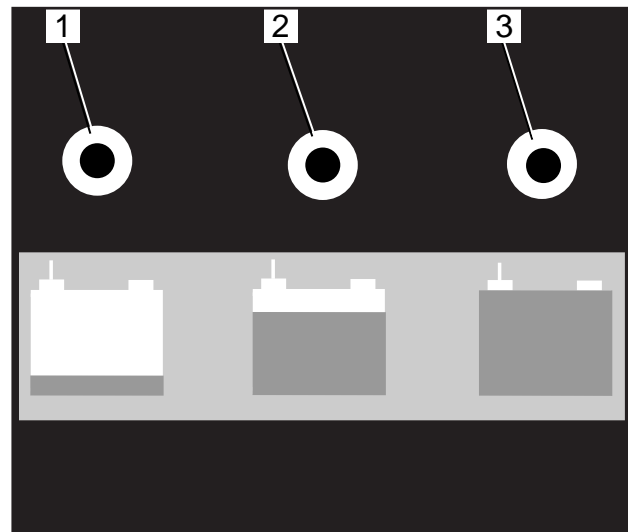

Fig. 23.1 Charging indicator

5.3.6 Master control

The master control allows the operator to raise and lower the working platform from the basket.

Pressing the “↑” button raises the basket.

Pressing the “↓” button lowers the basket.

When the buttons are released, the basket stops immediately.

The emergency stop switch (24/4) interrupts the functional elements of the working platform (refer to section 2.9.1).

When the chain break switch is triggered, the chain inspection light (24/1) goes on (refer to section 2.9.3).

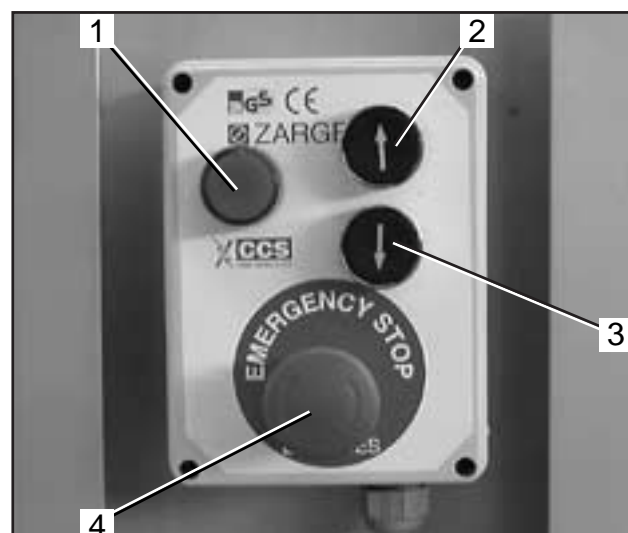

Fig. 24 Master control

5.4 Electro-hydraulic unit

5.4.1 230 VAC operation

The electro-hydraulic unit is installed in the trolley. The individual components are installed in or on the hydraulic oil tank (25/2). The hydraulic oil pump is driven by an electric motor and delivers the hydraulic oil via a pilot-controlled 3/2-port directional control valve (25/3) through the electrically-controlled emergency lowering device to the hydraulic cylinder. The operating pressure is limited to 100 bar with a pressure-relief valve. The connection to the hydraulic cylinder is made with hydraulic oil hoses.

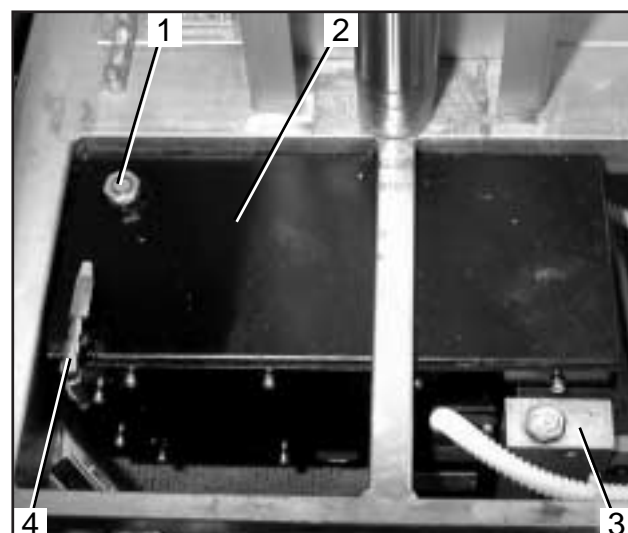

Fig. 25 Electro-hydraulic unit

The emergency lowering device is provided with a lowering stop valve (refer to section 5.4.4), which allows the lowering of the basket when the electrical system fails.

The oil level can be checked with the oil dipstick (25/1).

For the equalisation of the volume, the hydraulic oil tank is provided with a breather valve with filters (25/4). The valves are mounted so that an equalisation of volumina is possible when the working platform is tilted.



After the platform has stood a long time in the horizontal position, hydraulic oil can emerge from the valves so that the oil level in the hydraulic oil tank must be checked before resuming operation.



Leaked hydraulic oil should be removed immediately with an oil binding agent and stored and discarded appropriately.

5.4.2 24 V battery operation

The electro-hydraulic unit is installed in the trolley. The individual components are installed in or on the hydraulic oil tank (26/2). The hydraulic oil pump is driven by an external electric motor (26/4) and delivers the hydraulic oil via a pilot-controlled 3/2-port directional control valve (26/3) through the electrically-controlled emergency lowering device to the hydraulic cylinder. The operating pressure is limited to 100 bar with a pressure-relief valve. The connection to the hydraulic cylinder is made with hydraulic oil hoses.

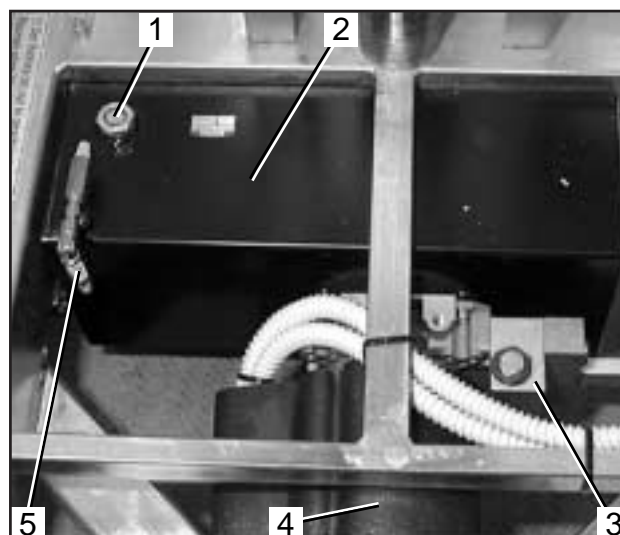

Fig. 26 Electro-hydraulic unit

The emergency lowering device is provided with a lowering stop valve (refer to section 5.4.4), which allows the lowering of the basket when the electrical system fails.

The oil level can be checked with the removable oil dipstick (26/1).

For the equalisation of the volume, the hydraulic oil tank is provided with a breather valve with filters (26/5). The valves are mounted so that an equalisation of volumina is possible when the working platform is tilted.



After the platform has stood a long time in the horizontal position, hydraulic oil can emerge from the valves so that the oil level in the hydraulic oil tank must be checked before resuming operation.



Leaked hydraulic oil should be removed immediately with an oil binding agent and stored and discarded appropriately.

5.4.3 Hydraulic schematic

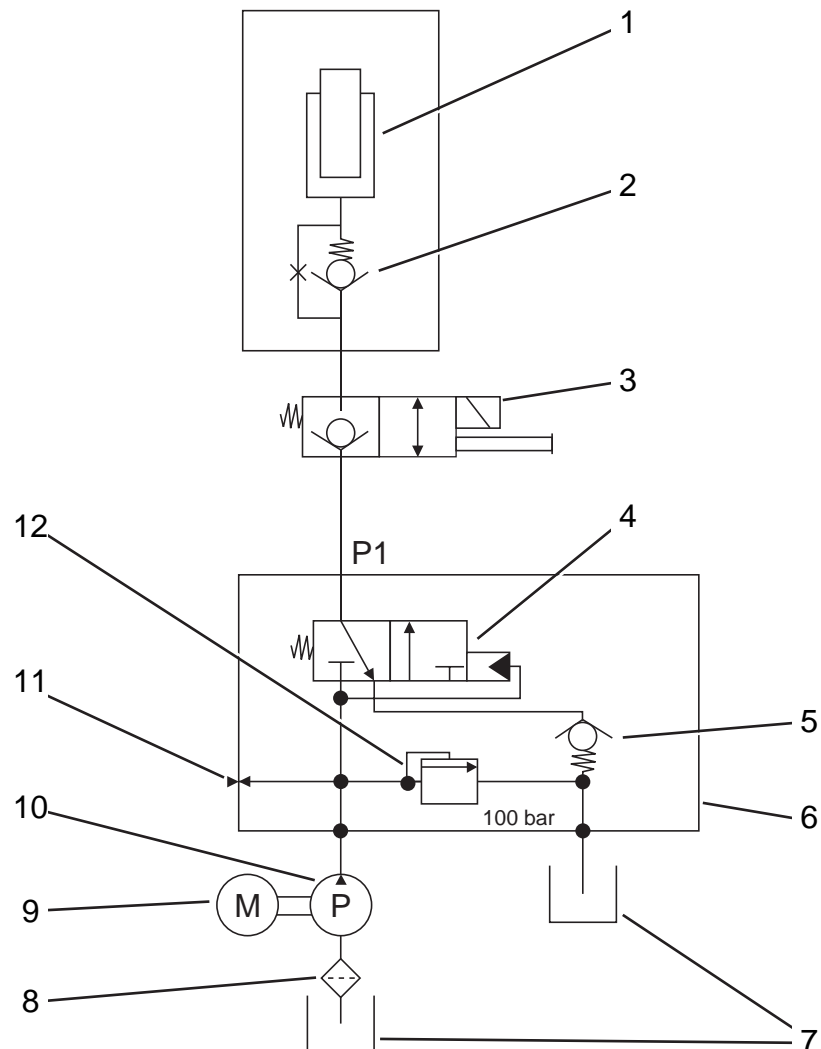

Fig. 27 Hydraulic schematic

- | | | | |
|---|------------------------------------|----|--------------------------------|
| 1 | Hydraulic cylinder | 7 | Hydraulic oil tank |
| 2 | Flow control valve | 8 | Suction filter |
| 3 | Lowering stop valve | 9 | Electric motor (24 V or 230 V) |
| 4 | 3/2-port directional control valve | 10 | Hydraulic oil pump |
| 5 | Check valve | 11 | Test port |
| 6 | Valve assembly | 12 | Pressure-relief valve 100 bar |

5.4.4 Emergency lowering device

The pressure in hydraulic cylinder can be relieved with the emergency lowering device (28/1) if the lowering stop valve can not be operated electrically.

To lower the basket, relieve the pressure by turning the knurled screw (28/2) anti-clockwise.

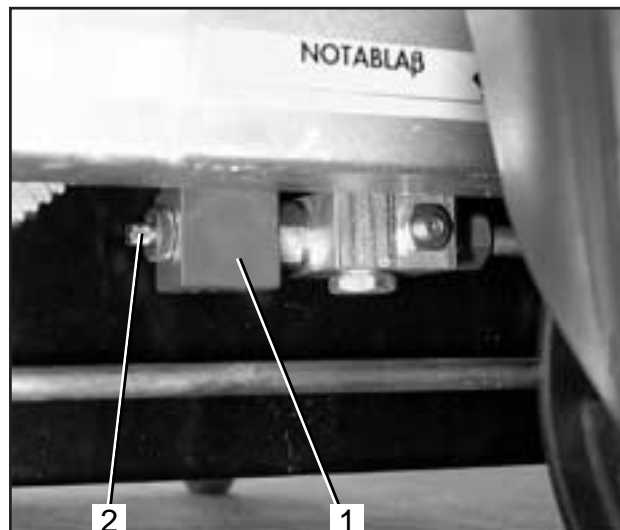

Fig. 28 Emergency lowering device

5.5 Basket

The basket (29/3) is made of extruded aluminium sections and rests on a support made of galvanized steel. The floor is made of bulb plate. The support is connected to the telescopic element with a pintle (29/4). The pintle is secured with a locking pin (29/1).

Regular entry is via a sliding cross bar (29/2). This cross bar can be lifted up to enter the basket. It drops through its own weight back to its initial position.

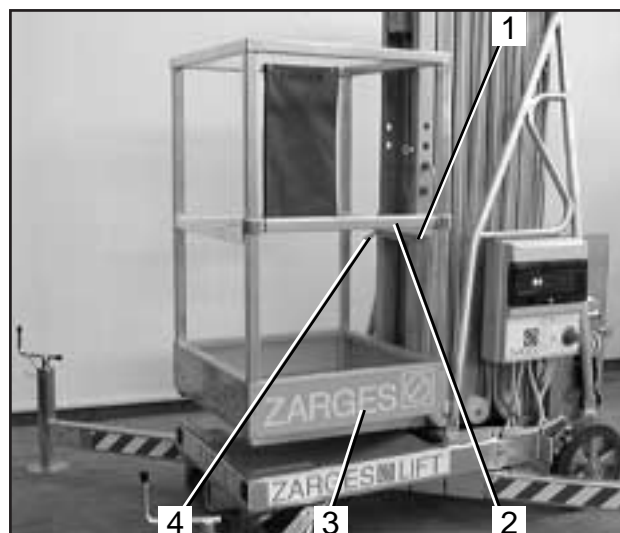

Fig. 29 Basket



The basket may only be entered through the regular entry. Climbing over the railing is forbidden. The basket may only be entered if the basket is fully lowered.

6 OPERATION

6.1 Safety rules

The working platform may only be operated in conformance with its approved use; any unapproved use is not allowed.

All safety rules in section 2 must be followed without deviation.

Only instructed and suitable persons familiar with the operating instructions may set up and operate the working platform. Two persons should operate the working platform.

Before using the working platform, check all components for proper condition and operability. When defects are found, the working platform may not be taken into operation.

Only undamaged and fault-free accessories from the manufacturer and referred to in the test certificate may be used.

The working platform may only be operated with the outriggers which are to be used for the relevant working area (inside/outside) and the working platform given in the model overview.

The working platform may only be operated with all four outriggers installed. The outriggers must be fully inserted in the trolley.

The working platform may only be set up vertically on horizontally level ground with a sufficient load capacity. If not, use load-distributing supports.

The outriggers of the working platform must be raised until all four wheels are fully off the ground.

During operation the switch box must be closed and the key must remain with the operator.

Only the connecting cables conforming to the technical data (refer to section 4.5) may be used for the electric connection of the working platform to a 230 VAC mains outlet. As power supply use a building site main cabinet. If this is not possible, protect the used socket with a type "C" line safety switch.

The battery charger of the 24 V battery-operated working platform may not be connected to a mains outlet during operation. The battery box door must be closed during operation.

The parking brake on the wheels may only be released for moving the working platform.

Before using the working platform, check that it is plumb vertical by using two water levels; correct the outriggers, if necessary.

When the working platform is set up in a traffic area, make the site safe by positioning warning barriers, warning lights or a flag man.

The load capacity of the basket (120 kg/basket for one person, 200 kg/basket for two persons, 120 kg/rotatable basket) may not be exceeded. The load capacity includes the operator and the materials/tools in the basket.

The operator must wear a hard hat when elevating the basket and working in it.

When elevating the basket, the operator must ensure that there is sufficient space between himself and the ceiling, protruding beams, etc. this applies in particular when the basket is being raised with the alternate control. → **Danger!**

The basket may only be entered through the regular entry and with the basket fully lowered.

When lifting or lowering the basket, the operator must ensure that the operator and other persons are not endangered.

Do not move the working platform with vehicles (e. g. fork trucks). Do not lift with the fork truck, pull or push the working platform.

Do not move working platform when raised.

The area on which the working platform is situated must be able to bear its weight.

Do not use the working platform with wind speeds of 2.7 m/s (10 km/h) and up. When wind comes up, stop work and lower the working platform.

Pay particular attention to wind conditions when using the working platform in buildings with through-traffic, at case buildings or building corners.

Do not use hoists on the working platform.

Do not lean against the side protection during work.

Do not jump into the basket.

Do not use planks etc. as a bridge from working platforms to buildings. The working platform must not be used as a staircase from which other constructions are accessed.

Do not create any horizontal loads, for example by working on adjacent constructions, as these may cause the working platform to tip over.

Do not increase the height of the platform with ladders, boxes or other devices.

When working on the platform, all the parts taken along must be secured or laid down so that falling down is excluded.

Do not stand under a raised basket (suspended load).

6.2 Initial operation

Before initial operation the working platform must be checked for conformance with the ordered model. The optional equipment must also be checked for completeness. Please notify ZARGES if parts are missing or defective.

Check all safety features for proper operation.

6.3 Basic assembly



Observe and adhere to the safety rules in sections 2 and 6.1.

Move the working platform to the site and apply the brake.

Slide all four outriggers (30/1) into the appropriate openings (30/2) in the trolley as far as the mechanical stop. The outriggers will lock automatically.

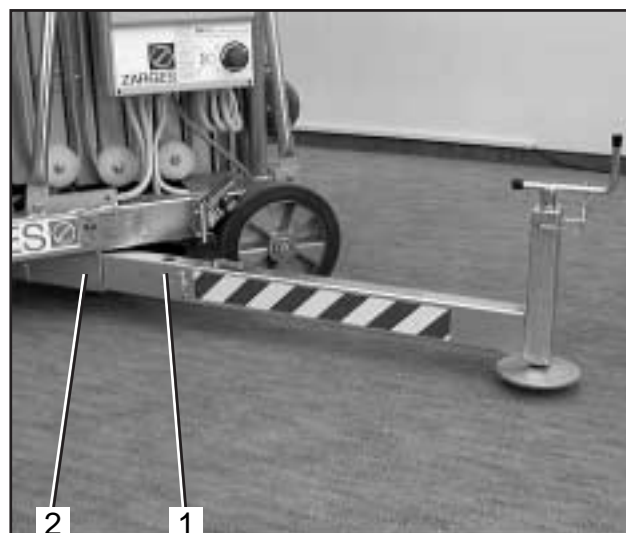

Fig. 30 Installation of the outriggers

Raise the working platform by turning the cranks (31/1) uniformly until all four wheels are off the ground.

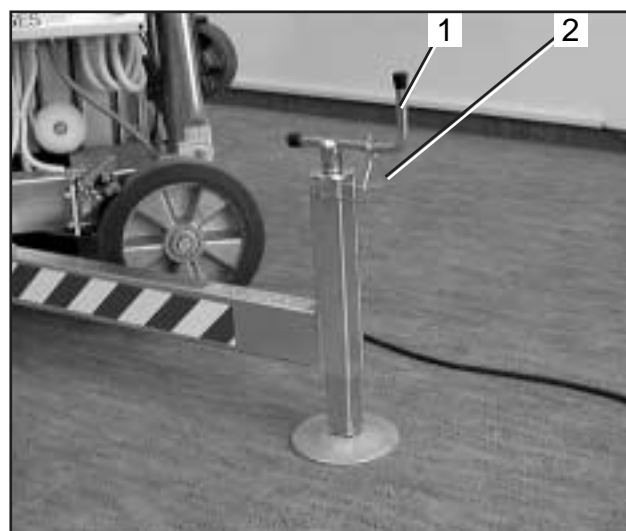

Fig. 31 Levelling the working platform

The working platform must be levelled so that the air bubbles in both water levels (32/1) are between the lines.



The levelling with the spindles must be very accurate as minimum deviations at ground level lead to substantial deviations at great height.

After the levelling procedure is completed, secure the cranks with the clips (31/2).

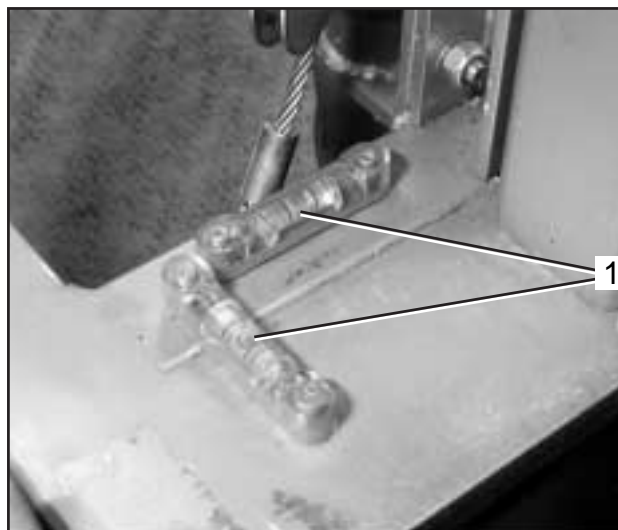

Fig. 32 Aligning the working platform

6.4 Connecting to the power supply



Connect the power cord to the power supply only after the basic assembly.

6.4.1 230 VAC operation

Plug the power cable on the switch box to the power supply with an extension cable.

Unlock the switch box and open the cover.

6.4.2 24 V battery operation

Hook the battery box with the plates (33/2 and 5) in the mounting holes (33/1 and 6) on the telescopic element. Use the grips (33/3) for lifting.



If the working platform is equipped with the tipper (option), the battery box must be positioned such that the plug (33/7) can be inserted into the socket (33/4).

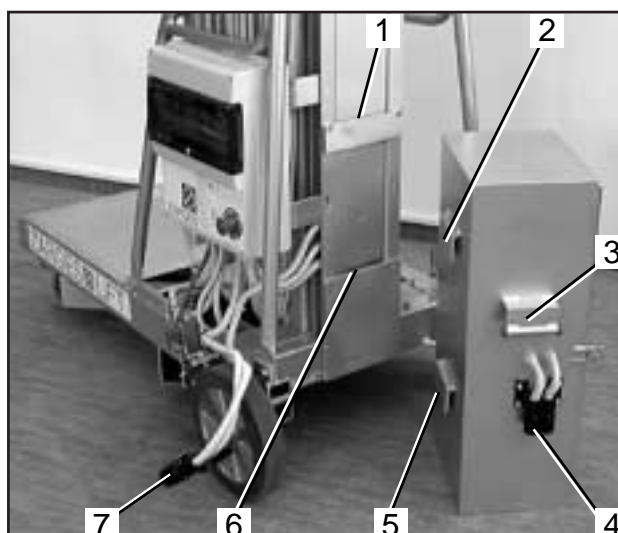

Fig. 33 Installing the battery box

Insert the plug (34/2) into the socket (34/1) at the battery box.

Unlock the switch box and open the cover.

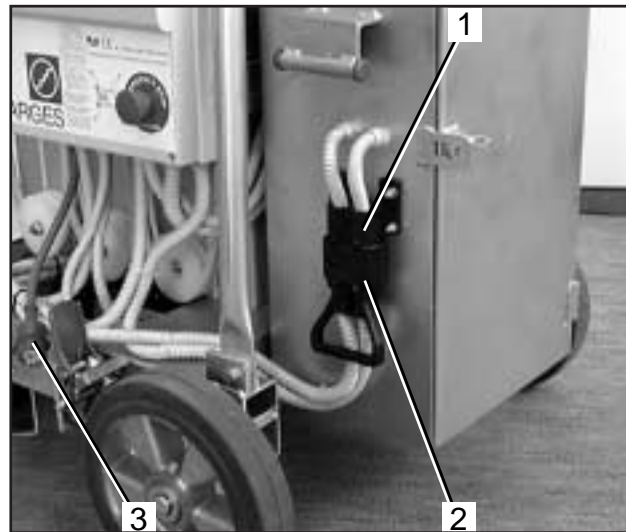

Fig. 34 Connecting the power supply

6.4.3 Connecting to power supply with the 230 V socket

Connect an extension cable to the plug (34/3) to provide the socket with power.

6.5 Operating the working platform



When operating the working platform, observe and adhere to the safety rules in sections 2 and 6.1.

6.5.1 Powering up, checking the indicators

230 VAC operation

Set the fault current circuit breaker (35/1) on the alternate control to the ON position.

The orange ready light (35/2) is illuminated.

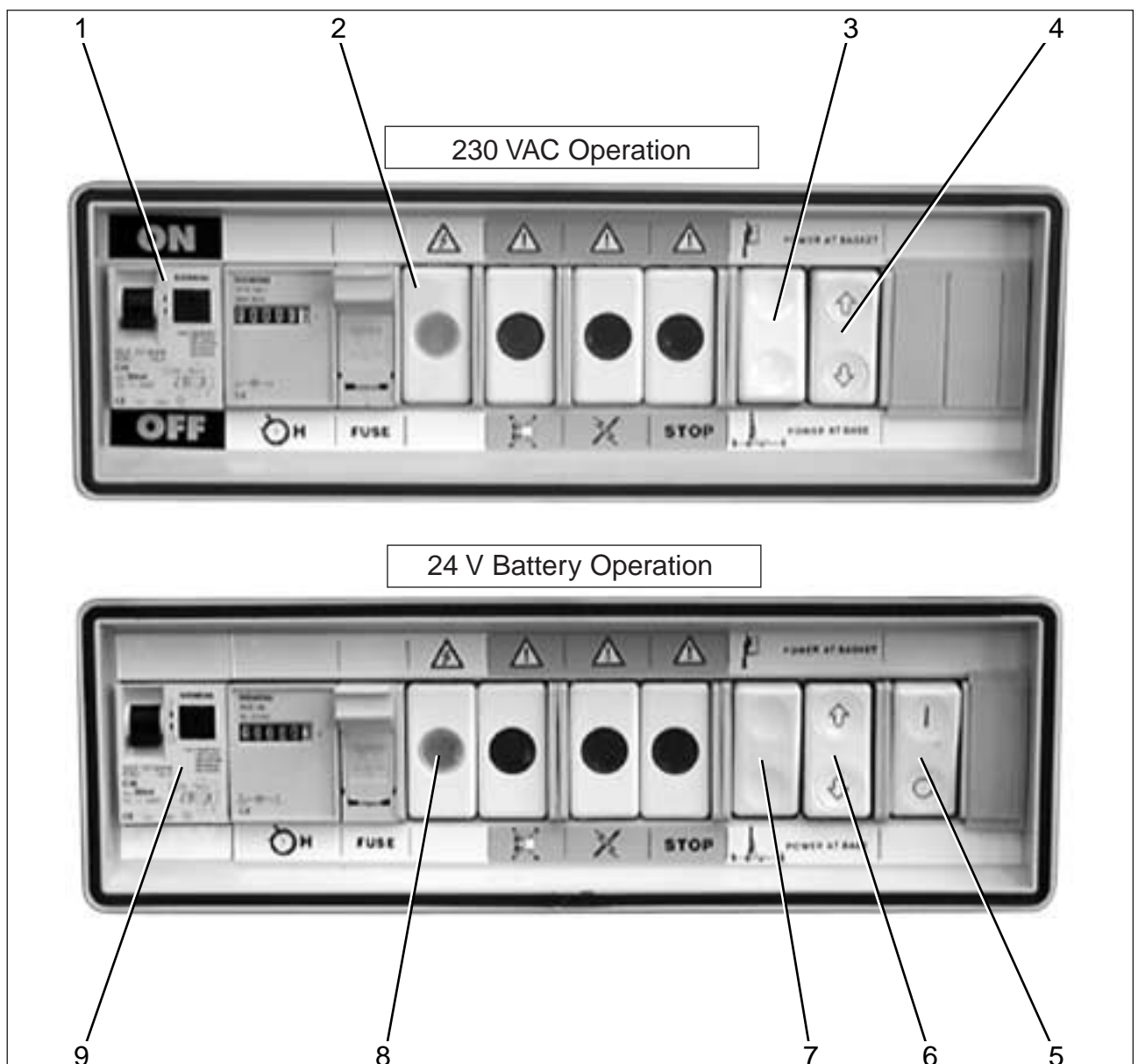

Fig. 35 Alternate control

24 V battery operation

Set the master switch (35/5) on the alternate control to position “I”.

The orange ready light (35/8) is illuminated.



If operation with the 230 V socket is planned, push up the fault current circuit breaker (35/9).

6.5.2 Selecting the operating position

If the working platform is to be operated with the master control, push the master/alternate control switch (35/3 or 7) **up**.

If the working platform is to be operated with the alternate control, push the master/alternate control switch (35/3 or 7) **down**.

6.5.3 Raising/lowering the working platform

Alternate control

Push the basket up/down switch (35/4 or 6) up to raise the basket.

Push the basket up/down switch (35/4 or 6) down to lower the basket.

Releasing the button stops the movement of the basket immediately.

Master control

Press the “↑” button (36/1) to raise the basket.

Press the “↓” button (36/2) to lower the basket.

Releasing the buttons stops the basket immediately.

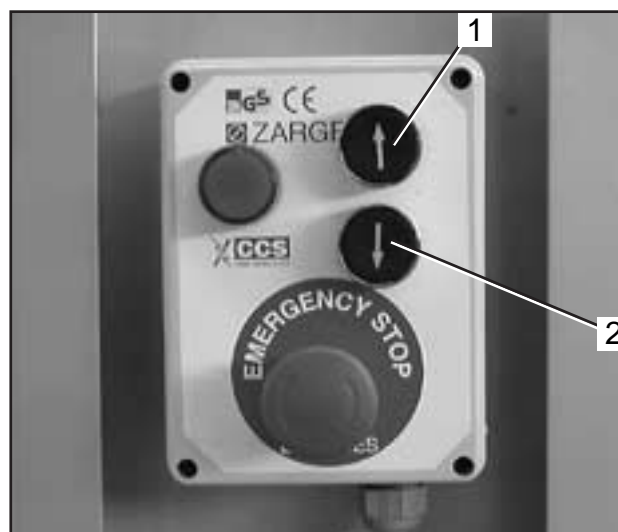

Fig. 36 Master control

6.6 Emergency lowering



The emergency lowering function may only be used when the electrical system fails. The operator in the basket and the person lowering the basket must maintain eye and voice contact.

For emergency lowering, turn the knurled screw (37/1) carefully and slowly. The lowering speed of the basket depends on how far the knurled screw is turned.



Fig. 37 Emergency lowering valve



Clear the area under the basket of persons and material before emergency lowering.

After the full lowering of the basket close the emergency lowering valve by tightening the knurled screw.

6.7 Operation of the emergency stop functions

When an emergency operation occurs, immediately press one of the two emergency stop switches (switch box/master control). This will interrupt the electric functions of the working platform immediately.

When an emergency operation is caused by the working platform, operation may only be resumed after the cause of the emergency situation has been remedied.

If the emergency operation was not caused by the working platform but by other influences, operation can be resumed by pulling out the emergency stop switch after the situation has been cleared.

6.8 Taking out of operation

Fully lower the working platform (refer to section 6.5.3).

Switch off the working platform by setting the fault current circuit breaker (35/1) (230 VAC operation) to the OFF position or the master switch (35/5) (24 V battery operation) to position "0".

When the 230 V socket is used, press the fault current circuit breaker (35/9) down if the working platform is operated with a 24 V battery.

Close the cover of the switch box, lock it and remove the key. The key remains with the operator.

Lower the outriggers with the cranks.



Before cranking the outriggers down, make sure that the parking brakes at the wheels are applied.

Pull up the release (38/1) at the outriggers and pull the outriggers out of the trolley.

On 230 VAC operated equipment, pull the extension cable out of the mains outlet and then from the plug at the switch box.

If the 230 V socket at the working platform is used with a 24 V battery, pull the extension cable out of the mains outlet and disconnect the plug at the cable connector.

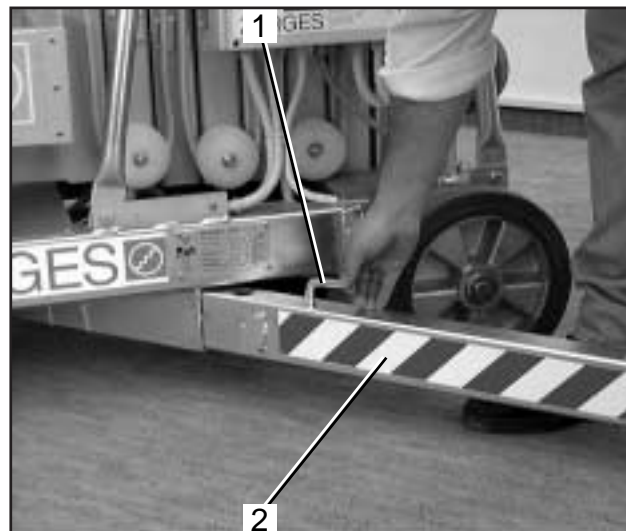

Fig. 38 Removing the outriggers

6.9 Removal and installation of the basket



This description applies for the removal and installation of a one- and two-person basket.

Removal

Pull the locking pin (39/1) out of the pintle (39/3).

Hold the basket with two person and pull out the pintle, lift the basket away from the working platform.

Installation

Installation is in the reverse order of removal.



When installing the pintle, make sure that it does not scrape the cable. The locking pin must be inserted in the pintle.

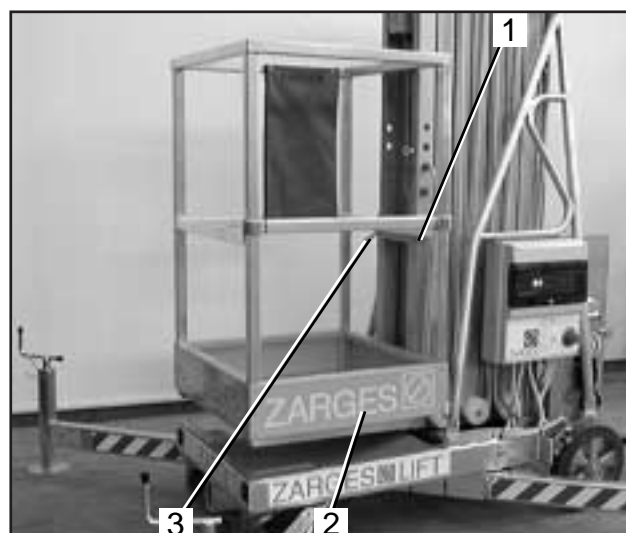

Fig. 39 Removal and installation of the basket

6.9.1 Higher mounting of the one-man basket

The one-man basket (39.1/1) can be mounted in the top hole of the first telescopic element (39.1/2). This increases the platform height by 0.9 m. The basket may be entered and left only over the ladder (39.1/3).



This measure is **only** allowed on working platforms with the Order No. 40163B, 40164B, 40167ST and 40168ST.

The installation is carried out as described in section 6.9.

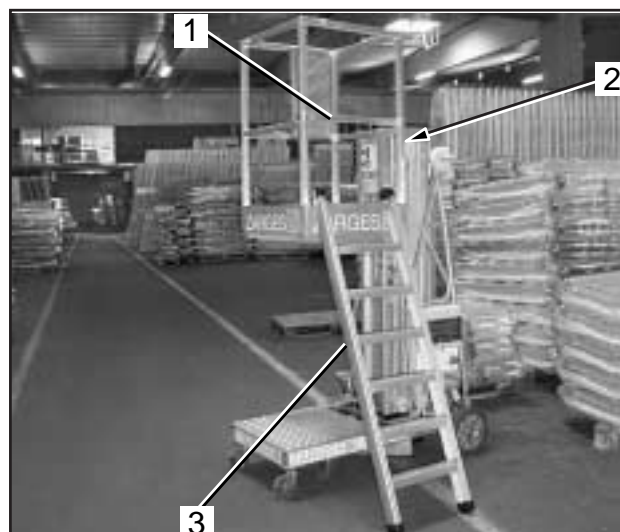

Fig 39.1 Higher mounting

6.10 Removal and installation of the rotatable basket

Remove and install the rotatable basket as described in section 6.9.



As the rotatable basket weighs 87 kg, the installation and removal must be performed with three persons.



Fig. 40 Removal and installation of rotatable basket

6.10.1 Operation of the rotatable basket

To release the rotatable basket, turn the rotary knob (41/1) anti-clockwise as far as possible.

Rotate the basket to the desired position.

Lock the basket in position by turning the rotary knob clockwise (as far as possible).



Working in the rotatable basket when it is not locked in position is forbidden.

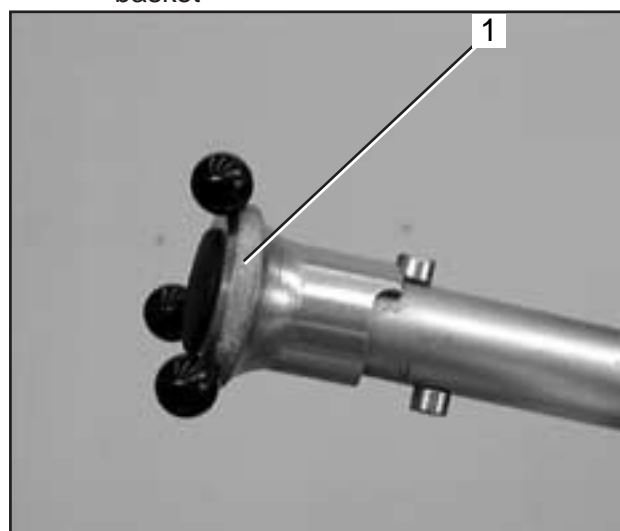

Fig. 41 Rotary knob

6.11 Tipper

6.11.1 Retrofitting the tipper

Install the support (42/1) on the telescopic element with 4 M8x40 screws, shims and self-locking nuts.

Install the mounting plate (42/4) on the telescopic element with 4 M10x40 screws, shims and self-locking nuts.



When tightening the screws, make sure that the cables are free to move.

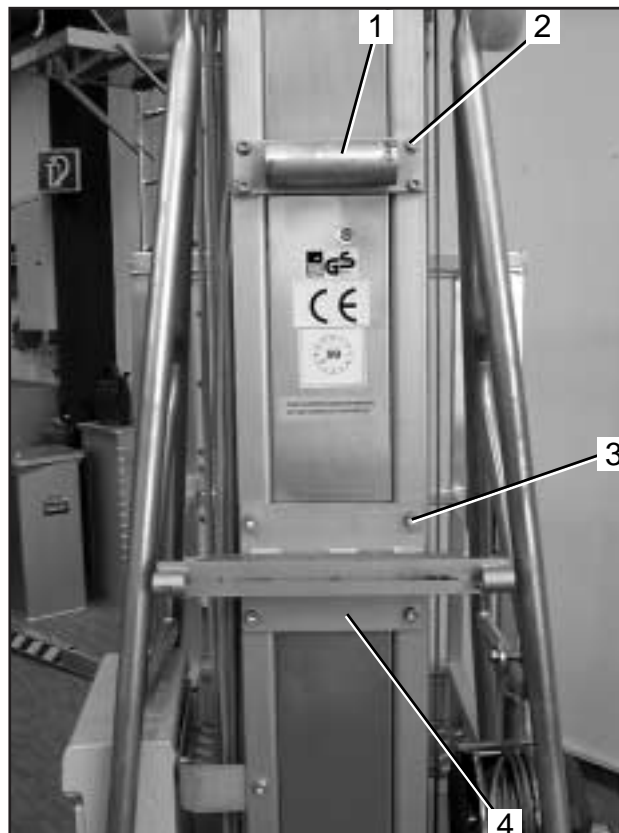

Fig. 42 Installing the mounting holes

Hook in the support fork (43/9) so that the lock (43/8) and the pulley (43/7) are mounted as shown in Figure 43. Fasten the support fork with the pintle (43/2) and locking pin (43/1).

Position the winch with cross member (43/4) as shown in Figure 43. Fasten the lower cross piece (43/5) with a M10x40 screw, shim and self-locking nut on the trolley. Fasten the top cross piece (43/3) with a M10x70 screw, shim and self-locking nut on the tube frame. Do not tighten the screw too much to prevent damage to the fork and the tube.

Attach the winch cable to the trolley with a shackle (43/6).

Remove the pulley from the fork and install the winch cable. Install the pulley and secure its axle with the locking pin.

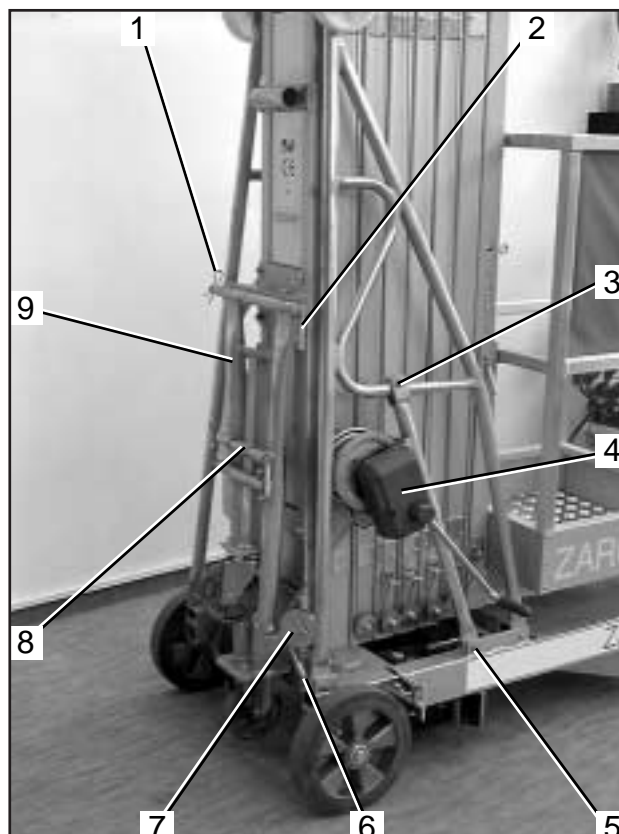

Fig. 43 Installing the tipper

6.11.2 Operation of the tipper



The working platform may only be tipped when lowered. Disconnect the power supply before tilting. At least two persons are required to tilt the platform.

Brake the working platform with the parking brake at the wheels.

Slide an outrigger approx. 0.4 m into each of the mounting holes (44/1) at the front of the trolley.



Fig. 44 Installing the outrigger

Pay out the winch cable until the marking on the cable is in the V-plate on the tube frame (45/3). Lower the support fork (45/5) so that the winch cable is held taut.

Pull out the pintle (45/4), tilt the support (45/1) as shown in Figure 45, insert the pintle and secure it with the locking pin (45/2).

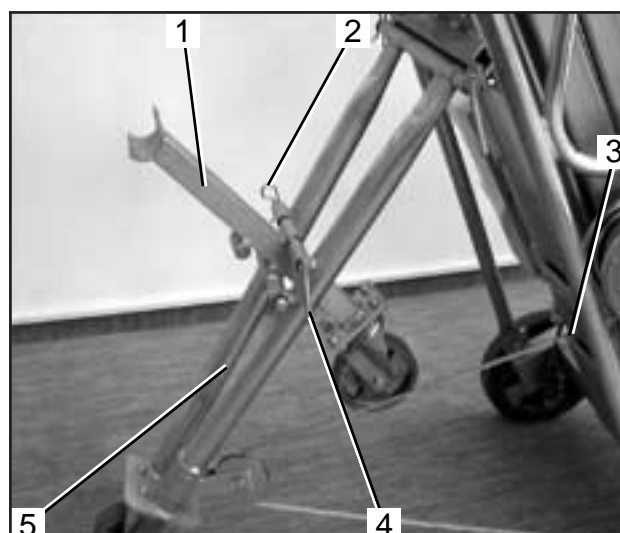

Fig. 45 Tilting the support

Let a helper raise the working platform carefully at the outrigger. While the platform is being raised, the operator must pull the support fork (46/2) away from the working platform so that the castor (46/1) touches the ground when the tip-over point is reached.

The winch cable must always be kept taut.



Fig. 46 Tilting the working platform

Tilt the working platform with the winch until the support rests on the support mounting (47/1).

Remove the outriggers from the base.

The tilted working platform can now be moved (refer to section 3.3.1).

To tilt back into the vertical position, perform the steps in the reverse order.



Fig. 47 Working platform tilted

6.12 Operation of the battery charger



Battery acid is very caustic. Always avoid contact with battery acid. If the clothing, skin or eyes have nevertheless come into contact with battery acid, rinse the affected areas immediately with water. In case of contact with the eyes, seek medical assistance immediately! Neutralise spilt battery acid immediately.



When working with batteries, use rubber gloves and goggles.



Charge batteries only in sufficiently ventilated rooms. Smoking, open fires or open flames are forbidden in these rooms.



When batteries are charged, detonating gas is released so that open flames can cause an explosion.



When charging deeply discharged batteries, remove the plugs from the batteries. When the batteries are only being recharged, the plugs can stay in the batteries. **Use a plastic or wooden lever to remove the plugs in order to prevent a short between the positive pole and the battery box.**



The batteries may only be charged if the power supply to the working platform is disconnected.



The minimum battery voltage must be 8 V, otherwise the charging procedure can not be started automatically. If necessary, the batteries must be charged with an external charger.

Open the battery box door fully.

Connect the mains plug (48/1) to a 230 VAC power outlet.



Fig. 48 Battery charger

The RED LED (48.1/1) illuminates at the start of the charging procedure.

The charging time for not completely discharged batteries is approx. 4 hours.

When the charging procedure is nearly finished, the YELLOW LED (48.1/2) flashes.

When the charging procedure is finished, the GREEN LED (48.1/3) illuminates.

- Disconnect the charger from the mains power supply and place the cable plug back into the battery box.
- Check the water level in the batteries, see section 8.4.5.



Bild 48.1 Charging indicator

7 TROUBLESHOOTING AND ELIMINATION OF FAULTS

The troubleshooting procedure contains only malfunctions and maloperations which can be remedied by the operator; any other malfunctions may only be eliminated by qualified personnel. Troubleshooting is performed with the aid of the troubleshooting chart. In order to localise a fault, first determine the fault of the working platform in the **fault** column. The **cause** column contains the reasons for the fault. The **remedy** column suggests the measure necessary to remedy the fault. Call qualified personnel if the fault can not be remedied by the action listed in the **remedy** column.

7.1 Safety rules

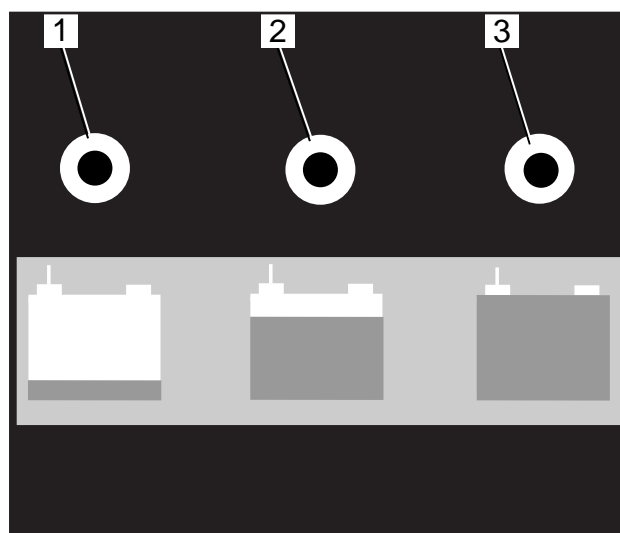
All the safety rules in sections 2 and 6.1 apply.

The operator may not open the electrical and hydraulic system. These services are reserved for qualified personnel.

Safety at and around the working platform must be ensured during troubleshooting.

If a problem on the working platform must be localised when the basket is raised, the operator should not stand under the basket except when the basket is secured against lowering with suitable measures.

7.2 Troubleshooting

Fault	Cause	Remedy
Starting up		
Ready light does not illuminate after powering up	Outriggers are not inserted as far as the stop (indicator light "Emergency stop at master control/outrigger not fully inserted" is illuminated).	Insert outriggers as far as the mechanical stop.
	Emergency stop button at the master control is pressed (indicator light "Emergency stop at master control/outrigger not fully inserted" is illuminated).	Pull out emergency stop button at the master control.
	500 V, 2 A fuse blown.	Switch off power supply to the working platform and renew the fuse.
	Battery voltage of working platform with 24 V battery operation is too low.	Disconnect the plug at the battery box and charge the batteries.
STOP warning light is illuminated after powering up.	Emergency stop button at the alternate control is depressed.	Pull out the emergency stop button at the alternate control.

Fault	Cause	Remedy
Operation		
Basket can not be raised with the master control	Master/alternate control switch is in the alternate control position.	Move master/alternate control switch to the master control position.
Basket can not be raised with the alternate control	Master/alternate control switch is in the master control position.	Move master/alternate control switch to the alternate control switch.
Basket rises too slowly (24 V battery operation)	Battery state of charge is too low.	Disconnect the plug at the battery box and charge the batteries.
Basket rises too slowly and drops slowly	Emergency lowering valve is not fully closed.	Close the emergency lowering valve.
Basket can not be raised fully	Oil level in the tank is too low.	Stop operation immediately and check the oil level.
No power at 230 V socket (24 V battery operation)	Fault current circuit breaker is not switched on.	Push fault current circuit breaker up.
Chain inspection light is illuminated	Flyer chain is either elongated or broken.	Stop operations immediately, close working platform for work, have damage repaired by qualified personnel.
Battery charger		
Batteries not being charged	Fuse in battery charger blown	See section 7.4.

7.3 Checking, renewing the fuse

Disconnect the working platform power supply and open the switch box, if necessary.

Open the fuse holder (49/1) and remove the fuse.

Check if the colour marking is present at one of the head ends. If the marking is missing, the fuse is defective and must be renewed.



Defective fuses may only be replaced with fuses of the same type and rating (refer to technical data in section 4.5).

Call a qualified electrician if the fault is not remedied by replacing the fuse or the fuse blows immediately after powering up again.

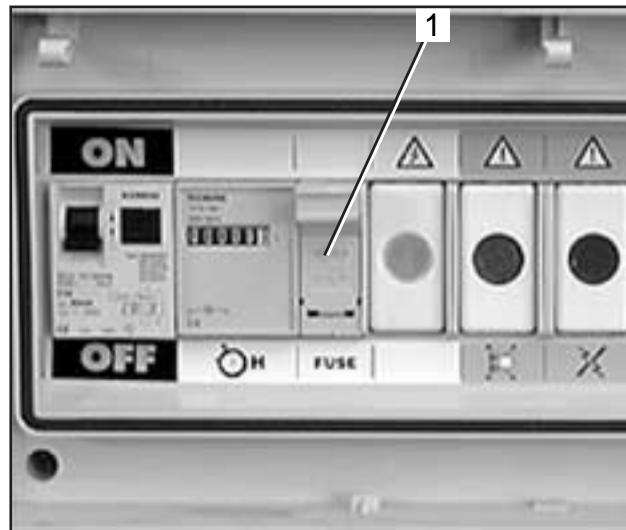

Fig. 49 Fuse

7.4 Replacing the battery charger fuse

- If required, disconnect the battery charger from the mains power supply.
- Pivot the battery charger out of the battery compartment until the fuse holder (49.1/1) is accessible.
- Open the fuse holder with a coin.
- Remove the fuse from the holder and replace with a fast-acting, 5 A fuse.



Fig. 49.1 Fuse



Defective fuses may only be replaced with fuses of the same type and rating.

Call a qualified electrician if the fault is not remedied by replacing the fuse or the fuse blows immediately after having connected the mains plug.

8 MAINTENANCE

The maintenance section includes all maintenance and care activities to be carried out on the working platform.

A careful maintenance of the working platform ensures a high degree of availability and increases the service life of assemblies.

Non-performance of the maintenance services or use of non-original parts will void the warranty and any claims against ZARGES GmbH & Co. KG.

8.1 Safety rules

Maintenance, cleaning and care activities may only be carried out if the working platform is fully switched off and the power supply disconnected. The working platform must be secured against powering up by locking the switch box.

Do not stand under the raised basket of the working platform unless the basket is secured against accidental lowering by appropriate measures.

Maintenance services may only be carried out by trained staff (refer to section 8.2).

If damage is detected during servicing, the working platform may only be returned to operation after the damage has been repaired. Repairs may only be carried out by qualified personnel.

The stability of the working platform must always be ensured during servicing.

All waste materials must be discarded in accordance with applicable environmental regulations.

8.2 Operating personnel qualifications

Operator

The operator may only carry out cleaning and care activities.

Qualified personnel

Qualified personnel is trained staff able to determine damage to the working platform and carry out maintenance and repair activities in the respective field (e. g. hydraulics, electrical engineering) due to technical training.

Work on the electrical system may only be carried out by skilled electricians qualified according to local standards (VDE 0100 in Germany).

Work on the hydraulic system may only be performed by trained hydraulic specialists.

8.3 Cleaning the working platform



Before beginning cleaning activities, disconnect the power supply to the working platform.



When using a steam cleaning machine for cleaning the working platform do not point the jet on the electrical components. The use of cleaning agents in the steam cleaning machine for the Flyer chains is forbidden.



Cleaning the working platform with inflammable fluids is forbidden.



Wash the working platform only at appropriate sites (oil and grease separators).

The working platform can be cleaned with water and a commercial cleaner. Take care that no water gets into the electrical system.

Clean plastic parts with a plastic cleaner.

The winch cable (when using the tipper, accessories) must be paid out fully and fastened to a fixed object. Clean the cable with a wire brush and then rub on hydraulic oil.

8.4 Maintenance schedule

When performing the maintenance services, the services for the previous periods must also be carried out, i. e. when doing the **annual** maintenance, the services for **semiannual**, **monthly** and for **each operation** must also be carried out.

Maintenance Interval	Service Point	Service	Performed by	Remarks
Before operation	Fault current circuit breaker	Check for operation	Operator	8.4.1
	Emergency stop device	Check for operation	Operator	6.7
	Working platform	Check for operation, condition and leaks	Operator	--
After operation	Batteries (24 V battery operation)	Charge	Operator	6.12
Monthly	Fault current circuit breaker	Check effectiveness	Skilled electrician	VBG 4
	Hydraulic oil tank	Oil level	Operator	8.4.2
	Wheels and castors	Condition, ease of movement	Operator	--
	Parking brake	Operation, setting	Operator	8.4.3
Semiannually	Trolley	Condition, cracks	Operator	--
	Outriggers	Condition, cracks	Operator	--
	Basket	Condition, cracks	Operator	--
	Swivel (rotatable basket, options)	Condition, axial play	Operator	Should not have play
	Spindles (outriggers)	Grease	Operator	8.4.4
	Batteries	Condition, clean connections, check electrolyte level and density	Operator	8.4.5
	Flyer chains	Visual inspection, clean and spray if necessary	Qualified staff	8.4.6

Maintenance Interval	Service Point	Service	Performed by	Remarks
Semiannually (continued)	Breather valve filters	Clean	Operator	8.4.7
	Winch cable	Clean, oil	Operator	8.4.8
	Winch, drive	Clean, grease	Operator	8.4.8
Annually	Working platform	Safety inspection acc. VBG 14 §39	Expert	9
Every six years	Hydraulic oil tank	Change hydraulic oil	Skilled staff	8.4.9
	Hydraulic oil hoses	Change	Skilled staff	8.4.9
	Suction filter, hydraulic oil tank	Change	Skilled staff	8.4.9
As required	Telescopic elements	Check play of nylon rollers on guides	Skilled staff	8.4.10

8.4.1 Check operation of the fault current circuit breaker



This check is required for working platforms operated with 230 VAC or 24 V batteries and using a 230 V socket.

Connect the working platform to the power supply (refer to sections 6.4.1 and 6.4.3).

Set the fault current circuit breaker to the ON position, i.e. up.

Press the test button (50/1). The fault current circuit breaker must immediately go to the OFF position, i.e. down, automatically. If this is not the case, the working platform may not be taken into operation. The fault must be remedied by a skilled electrician.



Fig. 50 Fault current circuit breaker

8.4.2 Check oil level in the hydraulic oil tank



Check the oil level only with the basket fully lowered.

Remove the oil dipstick (51/1) from the oil tank. The oil level must be between the high and low marks. The difference between the high and low marks is 2 litres. Only approved hydraulic oil may be filled (refer to section 8.5).

Fill hydraulic oil through the opening for the oil dipstick.



Fig. 51 Oil dipstick

8.4.3 Check, adjust adjustment of the parking brake



One of the two parking brakes must always be applied during the check and adjustment to prevent the working platform from rolling.

Apply the parking brake; the pin (52/1) must push about 3 to 5 mm into the wheel. If this is not the case, slacken the locknut (52/2) and screw the pin out of the actuating lever until the desired distance is reached.

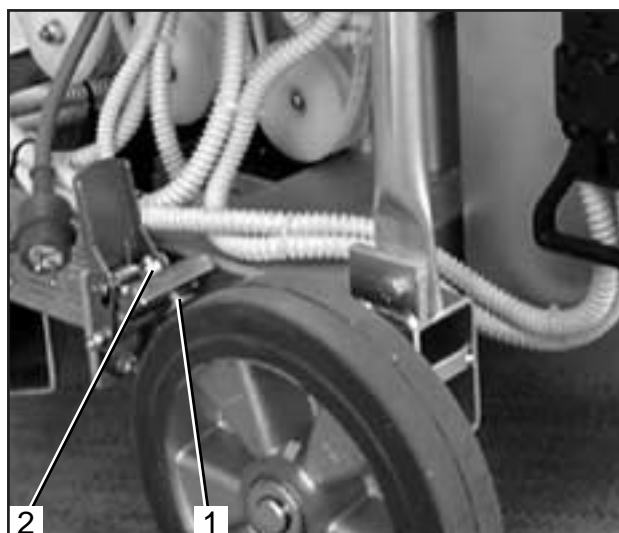

Fig. 52 Parking brake

8.4.4 Grease outrigger spindles

Using a grease gun, grease all four outriggers with lubricating grease (refer to section 8.5).

Apply three shots of grease per lubricating nipple (53/1). Distribute the grease by turning the spindles several times through the full cycle.



Fig. 53 Grease outrigger spindles

8.4.5 Check batteries (24 V battery operation)

Disconnect the power supply to the working platform and open the battery box.

Disconnect the batteries by always disconnecting the negative terminal first and reconnecting the positive terminal first.

Take the batteries carefully out of the battery box and deposit them on the ground.

Remove any traces of oxidation on the battery terminals and the battery clamps and clean the top of the battery.

Remove the plugs and check the electrolyte level. The electrolyte must be about 10-15 mm above the lead plates. Replenish the electrolyte with distilled water.

Check the acid-water density with a battery hydrometer. The reading on the hydrometer should be between 1.24 and 1.28 kg/l.

If the reading is under 1.24 kg/l, the battery must be charged. If the density between the various cells in one battery differs widely, the battery is probably faulty. The affected battery should be tested with a battery tester.



When changing one or both batteries, replace only batteries of the same type, with the same performance data and the same dimensions.

Before installation, coat the battery posts and clamps with petroleum jelly (white grease).

8.4.6 Check, clean and spray the Flyer chains



Raise the basket fully and secure it against accidental lowering (e. g. with chain attached to a roof beam).

Clean the Flyer chains thoroughly.

Check the Flyer chain for condition and wear, particularly in the area of the pulleys.

Check the mounting of the Flyer chain at the telescopic elements; damaged chains must be renewed.



Individual damaged or missing plastic links do not impair the function and service life.



If the accumulation of dust on the Flyer chains prevents the penetration of the lubricating oil, the chain must be cleaned.

Clean the Flyer chains

- Cover the trolley with a plastic cover.
- Clean the Flyer chains with paraffin derivatives such as benzine (observe the instructions of the manufacturer). **Do not use any cold cleaners, chemical cleaning agents or caustic or fluids containing acid or chlorine. Their use can lead to immediate damage to the chain.**



On working platforms used in the food industry, use a thin oil approved for the food industry instead of chain spray.

- When using a steam jet machine, do not use any additives.
- After completing the cleaning, immediately remove any water on the surface and in the joints of the Flyer chains with compressed air.
- Spray the Flyer chains with chain spray and move basket up and down several times through the full cycle.

8.4.7 Clean breather valve filters

Raise the basket about one metre and secure it against accidental lowering by placing a hardwood block underneath.

Remove both filters (54/1 and 2) from the breather valve and seal the openings.

Clean the filters with benzine and then blow dry with compressed air.

Renew the filters if the filter wire mesh is damaged or so restricted that cleaning is no longer possible.

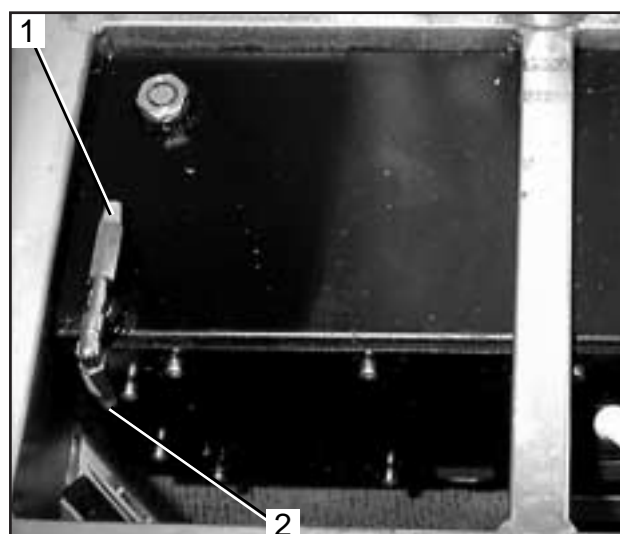

Fig. 54 Filter

8.4.8 Clean and service winch and winch cable

Winch

Clean the teeth (55/1) on the winch and grease with lubricating grease (refer to section 8.5).

Winch cable

Fully pay out the winch cable and attach to a fixed object. Pull the cable taut.

Check the winch cable for the following faults:

- heavy corrosion
- broken cable strands
- 10 visible cable breaks over 250 mm or 20 visible cable breaks over 1500 mm
- suberization
- basket formation
- looping of wires
- loosening of individual wires or strands
- knots
- necking
- flattening
- wave-type deformations
- kinks

If one or more of these faults are detected on the winch cable, the cable must be renewed.

Clean the winch cable with a wire brush without using cleaning agents; subsequently apply a light coat of hydraulic oil.

Oil the pulley (55/2) with hydraulic oil at the mounting.

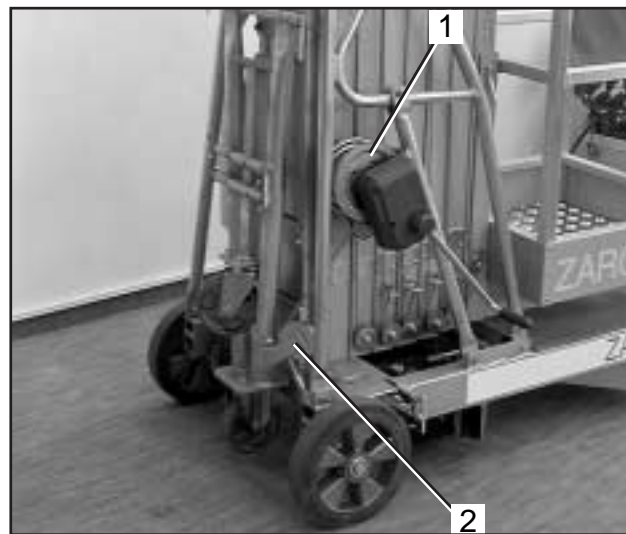

Fig. 55 Winch

8.4.9 Hydraulic system maintenance services

The hydraulic system maintenance services listed in the maintenance chart may only be performed by a skilled hydraulic technician.

Before beginning any work on the hydraulic system, first relieve the pressure in the system. This is done best at the test port. For this procedure the basket must be fully lowered.

Hydraulic oil may only be filled with the basket lowered. The filling quantity for an oil change is 11 litres. Only hydraulic oils may be filled which are listed in the table of recommended lubricants (refer to section 8.5).

Bleed the hydraulic system by raising and lowering the platform several times through the full cycle. The working platform may only be operated after all the air has been eliminated from the hydraulic system.

The renewal of the hydraulic oil and the hoses must be entered in the inspection booklet (refer to section 8.6).

8.4.10 Adjust nylon rollers on guides

The raising and lowering of the platform causes the nylon rollers to wear after a time. This wear is noticeable in the lateral movement of the telescopic elements. An limited adjustment is possible. The adjustment may only be performed by qualified personnel.

Remove the cover (56/1) at the telescopic elements on both sides.

Loosen the locknut (57/1) and turn in the screw (57/2).

Turning the screw in causes the nylon roller to move closer to the channel. Turn the screw in until the lateral play between the telescopic elements is eliminated.

Tighten locknut while holding the adjusting screw.



Fig. 56 Cover

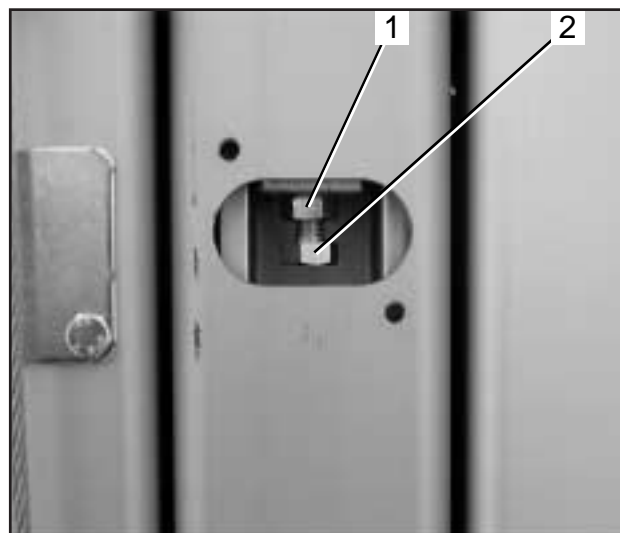

Fig. 57 Adjusting screw

8.5 Lubricants

Lubricant	OPTIMOL	Manufacturer:
Hydraulic oil	OPTIMOL HYDO 22	Optimol Ölwerke Industrie GmbH Friedenstraße 10 D-81671 München Tel.: 089/4183-0 Fax.: 089/4183-200
Chain spray	OPTIMOL VISCOGEN® KL	
Lubricating grease	OPTIMOL OLIT 2 EP	
Petroleum jelly	OPTIMOL OPTILEB VAS	
If you have any questions, contact Optimol Ölwerke Industrie GmbH.		

8.6 Inspection booklet

Your working platform was delivered with an inspection booklet. Important information related to the working platform must be entered into the inspection booklet.

This information includes, for example:

- the annual accident prevention rules-check,
- repairs on important assemblies (trolley, telescopic elements),
- renewal of the hydraulic hoses and the hydraulic oil.

8.7 Repair work on the working platform

The working platform may only be repaired by qualified personnel.

If repairs such as welding are performed on supporting parts, they must be inspected by an expert.

Use only genuine parts from the manufacturer for repairs.

After completion of repairs, the working platform may only be taken into operation after its proper operation has been established. During this inspection particularly close attention must be paid to the repaired areas and the safety features.

8.8 Spare parts

Original spare parts are available from ZARGES GmbH & Co. KG. When ordering parts, please state the model and the installed optional equipment.

9 ACCIDENT PREVENTION RULES-CHECK

The basis for the performance of the accident prevention rules-check are local regulations (to VBG 14 and ZH 1/490 in Germany). If the working platform is equipped with the tipper (option), the winch must also be inspected (to BGV D 8 (formerly VBG 8) in Germany).

According to the accident prevention rules of the trade associations, the working platform must be inspected at least once a year by a specially trained person (expert). This person must have sufficient knowledge of working platforms on the basis of his training and experience and be familiar with the applicable national worker's protection legislation, safety legislation and generally recognized rules of the art that he can ascertain that the working platform is safe to use. The expert must make a neutral assessment and evaluation without the influence of personal, economic or company interests. A visual inspection and operational check must be carried out during which all components are inspected for condition, completeness and the effectiveness of the safety features.

The performance of the check must be entered as inspection result in the inspection booklet. The minimum information required is the following:

- Date and scope of the inspection, stating which subtests still need to be carried out,
- result of the inspection giving the defects found,
- evaluation of continued operation,
- information on required after-checks and
- name, address and signature of inspector.

The operator (owner) is responsible for the observation of inspection deadlines. The recognition and elimination of the detected faults must be confirmed by the owner in writing in the inspection report stating the date.

10 TAKING OUT OF OPERATION AND STORAGE

When the working platform is taken out of operation for over two months, the measures before, during and after taking out of operation must be performed as described below. When the platform is taken out of operation for over six months, additional measures must be checked with the manufacturer.

10.1 Safety rules

All the safety rules in sections 2, 6.1 and 8.1 must be observed.

As long as the platform is taken out of operation, it must be secured against unapproved use.

10.2 Storage conditions

The storage place must be have a bearing capacity high enough for the weight of the working platform.

The storage place must be free of frost, dry and well ventilated.

The storage place for the battery box (24 V battery operation) must be well ventilated and have a 230 VAC power outlet.

10.3 Measures before taking out of operation

Thoroughly clean the working platform (refer to section 8.3).

Check the hydraulic oil level, add oil if required (refer to section 8.4.2).

Clean and oil the winch cable if the tipper (option) is used (refer to section 8.4.8).

Check the condition of the batteries, clean if required (refer to section 8.4.5).

Move the working platform to the storage place (refer to section 3.3).

If possible with regard to space, mount outriggers and raise working platform, until the wheels are off the ground. If this is not possible, the trolley must be put on wood blocks.

Cover working platform with cotton cloths.

10.4 Measures during storage

Connect battery charger, refer to section 6.12. The battery charger can stay connected during storage, the charging current will automatically be adapted to the battery.

10.5 Taking back into operation after storage

Thoroughly clean the working platform if required.

Check hydraulic oil for condensation, change oil if required.

Check safety features for proper operation, refer to section 6.7 and 8.4.1.

Take into operation acc. to section 6.3 and following, if faults are detected, operation may be taken up only after remedy of the fault.

If during the storage the accident prevention rules-check has been due, this check is to be performed before taking back into operation.



EC Attestation of Conformity

**in accordance with EC Guidelines for Machines 89/392/EEC, Appendix II A
for Machine Types to Appendix IV
EC Guidelines for Electromagnetic Compatibility 89/336/EEC
EC Guideline "Low Voltage" 73/23/EEC**

The machine design

Make: Zarges-Lift

Type designation: 40163B, 40164B, 40165B, 40166B, 40167ST, 40168ST, 40169ST and 40170ST

has been developed, designed and manufactured in accordance with the aforementioned EC guidelines at the sole responsibility of

ZARGES GmbH & Co. KG.

The following harmonised standards have been applied:

- DIN EN 292 -- Safety of Machines, Equipment and Installations
- EN 349 -- Machine Safety
- EN 414 -- Machine Safety
- EN 418 -- Machine Safety
- DIN EN 60 204.1 -- Electrical Equipment of Machines
- prEN 280 -- Moveable Lifting Platforms

The following standards were used to assess the product in respect to electromagnetic compatibility:

- DIN EN 50081-1 : 1992
- DIN EN 50082-2 : 1995
- DIN EN 61000-3-2 : 1995
- DIN EN 61000-3-3 : 1995

The registered authority

TÜV PRODUCT SERVICE GMBH - Zertifizierstelle - Ridlerstrasse 31- D-80339 München,

has been commissioned to

- file the documents in accordance with Appendix VI EC of guideline 89/392/EEC
- check the correct application of the harmonised standards and with confirmation
- check that the specified documents to Appendix VI EC of guideline 89/392/EEC are included
- **EC Homologation, Test Certificate No. M6 99 05 12881 128**

ZARGES GmbH & Co. KG
Anwendungstechnik - Steigtechnik
Zargesstraße 7
82362 Weilheim

Weilheim, 7th of July 1999

City, Date	Signature	Firm-Stamp
------------	-----------	------------

This certificate will be voided if the Zarges lift is modified without the express permission of the manufacturer.

Warranty Card

Operator:	Equipment: Zarges Lift
Surname:	Model:
First name:	Series number:
Street:	Date of purchase:
City:	Please complete the warranty card legibly and send to ZARGES GmbH & Co. KG within 20 days of receipt of the Zarges lift.
Signature:	<p>ZARGES products are made from high-quality, selected materials. Before shipment, they are inspected carefully. For this reason we can warrant Zarges lifts for one year from the date of shipment. The warranty is on all defects in material, workmanship and design for which we are responsible. A condition for the warranty is the approved use of the Zarges lifts as described in the Operating Instructions and the observation of all safety and maintenance notes therein.</p> <p>Excluded from the warranty are all wear parts, the batteries and flexible electrical and hydraulic lines.</p> <p>Not included in this warranty are: natural wear, damage due to acts of God, damage caused by improper operation and modification of the article.</p> <p>Warranty shall be rendered either by reworking or replacement with an equivalent article. Follow-up damage is excluded. The elimination of faults does not start a new period of warranty. Defective articles must be returned to us directly free of delivery charge.</p>

From

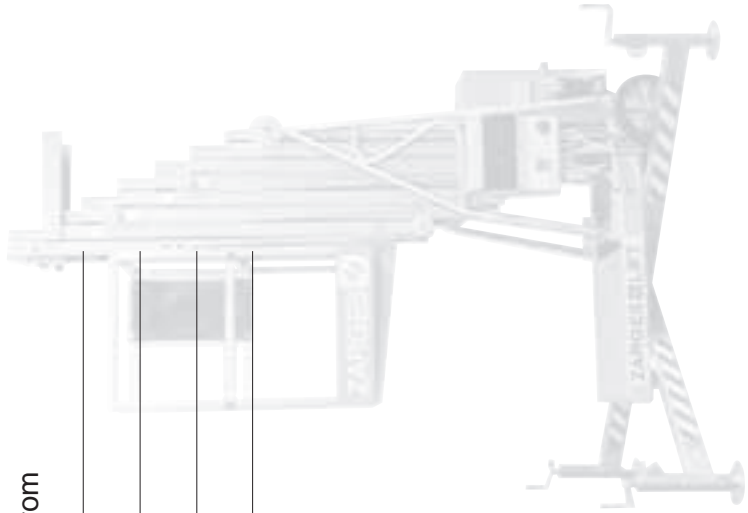

please
affix stamp

**Firma
Zarges GmbH & Co. KG
Postfach 16 30
D-82360 Weilheim i. OB
Germany**

