



ZARGES



Information Brochure and Assembly and Use Instructions

Issue 2011

Arrester System ZAST

GB

No. 291333



ZARGES

If you need further information or if special problems should arise which have not been adequately described in these Assembly and Use Instructions, please contact the manufacturer directly for the required information (see Section 1.2).

We also would like to point out that the contents of these Assembly and Use Instructions are not part of an earlier agreement, promise or any legally binding relationship or that they should change these. All obligations arise from the relevant sales contract, which also contains the complete and only valid conditions of guarantee (also see Section 2.2). These contractual guarantee conditions are neither expanded nor restricted by the information in these Assembly and Use Instructions.

The transmission and reproduction of this document, the utilization and disclosure of its contents are allowed only with the express approval of the manufacturer. Any violations contravening the aforementioned statements will require payment of damages.

Technical changes affecting the arrester system may not be included in these Assembly and Use Instructions. If you have any questions, please contact the manufacturer.

Contents

Page

1	GENERAL	5
1.1	Introduction	5
1.2	Manufacturer	5
1.3	Homologation	6
1.4	Issue No. and/or date of issue	6
1.5	Copyrights	7
1.6	Personnel requirements	7
2	SAFETY RULES	7
2.1	Basic safety precautions	7
2.2	Duties, liability and guarantee	8
2.3	Approved use	10
2.4	Misuse	11
2.5	Special duties of owners	11
2.6	Safety features	11
3	DESCRIPTION	12
3.1	Technical data	12
3.2	Type plates	12
3.3	Overview of models and description of components with single parts and accessories	14
4	INSTALLATION	24
4.1	Safety rules	24
4.2	Installation of arrester system in the centre of ladder rungs	27
4.3	Installation of arrester system laterally on the stile	28
4.4	Installation of arrester system on single-row manhole steps	30
4.5	Installation of arrester system with two-row manhole steps	31
4.6	Installation of single stile ladders with integrated arrester rail	32
4.7	Installation of folding rest platform	34
4.8	Installation of swivel plates	35
4.9	Installation of the pin for rail access extension (Order No. 47563/47573)	38
4.10	Installation of the rail stops	39
4.11	Plugs	42
4.12	Post-installation activities	42



ZARGES

5	OPERATION OF THE ARRESTER SYSTEM.....	43
5.1	Safety rules and precautions	43
5.2	Entering and exiting the arrester system	45
5.3	Using the swivel plate vertically and horizontally to the left	47
5.4	Using the swivel plate vertically and horizontally to the right	48
5.5	Using the swivel plate vertically and horizontally	49
5.6	Using the folding rest platform	51
6	MAINTENANCE, CARE AND STORAGE	52
6.1	Maintenance and care	52
6.2	Storage	53
6.3	Transport	53
6.4	Packaging	53
7	RESCUE MEASURES	53
8	INSPECTIONS	54

1 GENERAL

1.1 Introduction

These Assembly and Use Instructions apply only for the ZARGES arrester system ZAST approved as indicated in section 1.3, “Homologation”. In the following the expression arrester system is used.

The safety notes, rules and regulations in these Assembly and Use Instructions related to the operation of arrester systems apply to the arrester systems mentioned in this documentation.

It is solely the responsibility of the owner to:

- ensure that local, regional and national regulations are observed,
- observe the rules (legislation, regulations, guidelines, etc.) in these Assembly and Use Instructions for safe handling,
- ensure the Assembly and Use Instructions/information brochure are made available to installation and operating personnel and that the information, notes, precautions and safety rules are observed as detailed.
- **The user of the arrester system must have read and fully understood the safety rules and precautions. In case of questions, he should ask his supervisor.**

1.2 Manufacturer

The manufacturer of the arrester systems described in this documentation is

Firma ZARGES GmbH
Sparte Steigtechnik
Abt. Schachttechnik/Steigleitern
Postfach 1630

Tel.: 08 81/68 71 04
Fax: 08 81/68 73 72
E-mail: schachttechnik@zarges.de
Internet: <http://www.zarges.de>

82360 Weilheim

1.3 Homologation

The EC type test of the arrester system mentioned in the following was performed by

Berufsgenossenschaftlichen Institut für Arbeitssicherheit - BGIA
Alte Heerstraße 111

53754 Sankt Augustin.

The inspection of the arrester system mentioned in the following is carried out by

Berufsgenossenschaftliche Institut für Arbeitssicherheit - BGIA
Alte Heerstraße 111

53754 Sankt Augustin

under the code number 0121.

The arrester systems conform to standard EN 353-1 and are marked with the

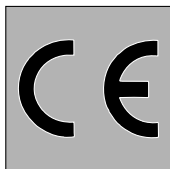

symbol.

1.4 Issue No. and/or date of issue

The date of issue of these Assembly and Use Instructions is March 01, 2011.

1.5 Copyrights

- The copyright for these Assembly and Use Instructions remains with the manufacturer.
- Furthermore, all rights are reserved, in particular in the case of the granted patent and utility-model patents.
- Any violations of these conditions will require compensation.

1.6 Personnel requirements

1.6.1 Assembly personnel

The installation of the arrester system or the single stile ladder may only be carried out by skilled personnel.

1.6.2 User personnel

The user of the arrester system or the single stile ladder must know how to operate the arrester system. The user must be physically capable of climbing the ladder system with arrester system.

2 SAFETY RULES

2.1 Basic safety precautions

The following regulations apply for the installation and use of the arrester systems and the single stile ladders:

- BGV A1 “Allgemeine Vorschriften”
- BGV C22 “Bauarbeiten”
- BGV C5 “Abwassertechnische Anlagen”



- BGV D36 “Leitern und Tritte”
- BGG 906 “Grundsätze für Auswahl, Ausbildung und Befähigungsnachweis von Sachkundigen für persönliche Schutzausrüstungen gegen Absturz”
- BGI 530 booklet “Hochbauarbeiten”
- BGR 177 “Sicherheitsregeln für Steigeisen und Steigeisengänge”
- BGI 691 “Regeln für das Nachrüsten von Steigeisen- und Steigeisengängen mit Steigschutzeinrichtungen an Schornsteinen”
- BGR 198 “Regeln für den Einsatz von persönlichen Schutzausrüstungen gegen Absturz”.

2.2 Duties, liability and guarantee

A prerequisite for the safe and problemfree installation and use of the single stile ladders and arresters is a knowledge of the safety precautions and the safety rules. These Assembly and Use Instructions, especially the safety precautions, must be followed by all persons installing and using the single stile ladders or the arrester systems. Beyond this, the local safety rules and regulations must also be observed.

Potential hazards arising during the use of the arrester system:

- The single stile ladder and the arrester system are built according to the state of the art and the recognised safety rules. Nevertheless, danger to life and limb of the user or third persons, impairments to the arrester system or other property can occur during assembly and use. The single stile ladder and the arrester system may only be used

--> for the approved use and

--> if in a perfectly safe condition.

Malfunctions which could reduce safety must be remedied immediately.

Guarantee and liability

The scope and period of the guarantee are set forth in the manufacturer's sales and delivery conditions. For guarantee claims based on deficiencies in the documentation, the Assembly and Use Instructions valid at the time of delivery shall apply (see Section 1.4). The following applies beyond the scope of the sales and guarantee conditions: No liability is given for personal injuries or property damage due to one or more of the following reasons:

- misuse of the arrester system
- improper mounting and use of the arrester system,
- use of the arrester system with defective safety features or improperly mounted or malfunctioning safety and protective devices,
- ignorance or nonobservance of these Assembly and Use Instructions,
- insufficiently qualified or insufficiently instructed assembly and user personnel,
- improperly carried out repairs,
- use of non-genuine spare parts,
- unapproved design changes to the arrester system,
- improper inspection of components subject to wear and tear,
- catastrophes caused by foreign objects and acts of God.



The owner or the installation firm must ensure at its own responsibility

- that the safety rules in Section 2 ff. are observed,
- that misuse (see Section 2.4) and faulty assembly, unapproved use are excluded and
- that the proper and approved use (see Section 2.3) is ensured and the arrester system is operated in conformance with the conditions of use stipulated in the contract.

2.3 Approved use

The single stile ladders described in these Assembly and Use Instructions may only be used for climbing buildings and manholes by persons wearing personal protective equipment. The installation may only be carried out by skilled personnel.

The arrester systems described in these Assembly and Use Instructions may only be used for climbing buildings and manholes by means of ladders or step irons by persons wearing personal protective equipment. The installation may only be carried out by skilled personnel.

Approved use also includes:

- the observation of all notes in these Assembly and Use Instructions and
- regular safety inspections.



2.4 Misuse

An improper use - ie any deviation from the information on the documented arrester systems given in Section 2.3 of these Assembly and Use Instructions - is a **misuse** in the sense of the GPSG (issue: May 1, 2004). This also applies for the nonobservance of the standards and guidelines listed in these Assembly and Use Instructions.

Hazards can arise in case of misuse. Misuse includes, for example, using the personal protective equipment to transport loads.

2.5 Special duties of owners

According to BGR 198, each owner must prepare operating instructions for the personal protective equipment and familiarise the users therewith.

The owner must also instruct the user once every year on the basis of these operating instructions.

The slide mechanism, which is part of the personal protective equipment, is supplied with an inspection card acc. to DIN EN 365. The owner is responsible for the completion and storage of the inspection card. The owner must enter any missing data on the inspection card with a ball point pen or felt marker immediately after receipt of the slide mechanism.

2.6 Safety features

Before each use, the slide mechanism, shackles, and the energy-absorbing strap element must be inspected for proper condition and operation. Furthermore, the stops at the entrance or exit points must also be checked for proper condition and operation.

Any manipulation of the aforementioned components is prohibited. If a defect is determined, do not use the slide mechanism and its connecting parts.



3 DESCRIPTION

3.1 Technical data

Length:

ZAST-type arrester rail	1.40 m, 1.96 m, 2.80 m
Single stile ladder	1.40 m, 1.96 m, 2.80 m
Rail access extension	approx. 1.40 m
Pin (for rail access extension)	approx. 0.25 m

Weight:

Slide mechanism with ZAST-type connector	
- stainless steel	approx. 1.6 kg
- aluminium and stainless steel	approx. 1.3 kg
ZAST-type swivel plate	
- stainless steel	5.1 kg
- galvanized steel	5.3 kg

3.2 Type plates

Type plates (1) are attached to all arrester system and the single stile ladder components.

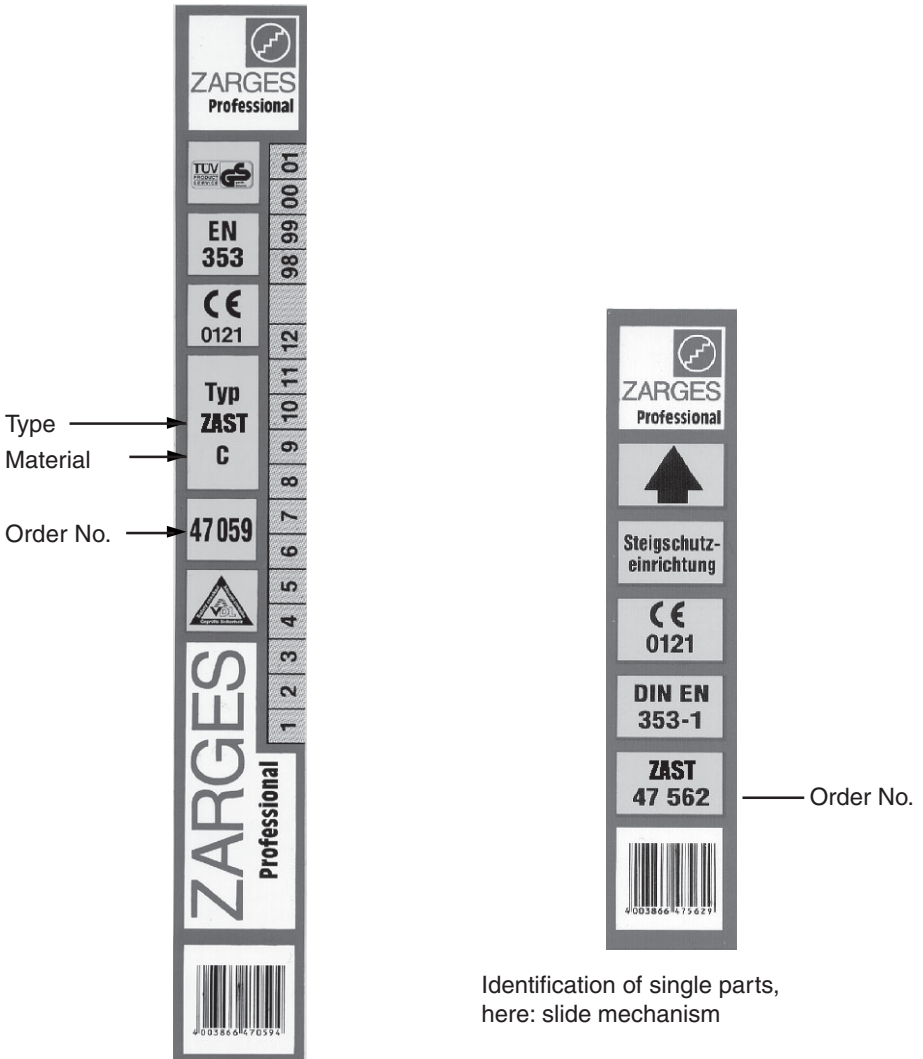

Identification of arrester rails or single stile ladders

Identification of single parts, here: slide mechanism

Fig. 1 Type plates



3.3 Overview of models and description of components with single parts and accessories

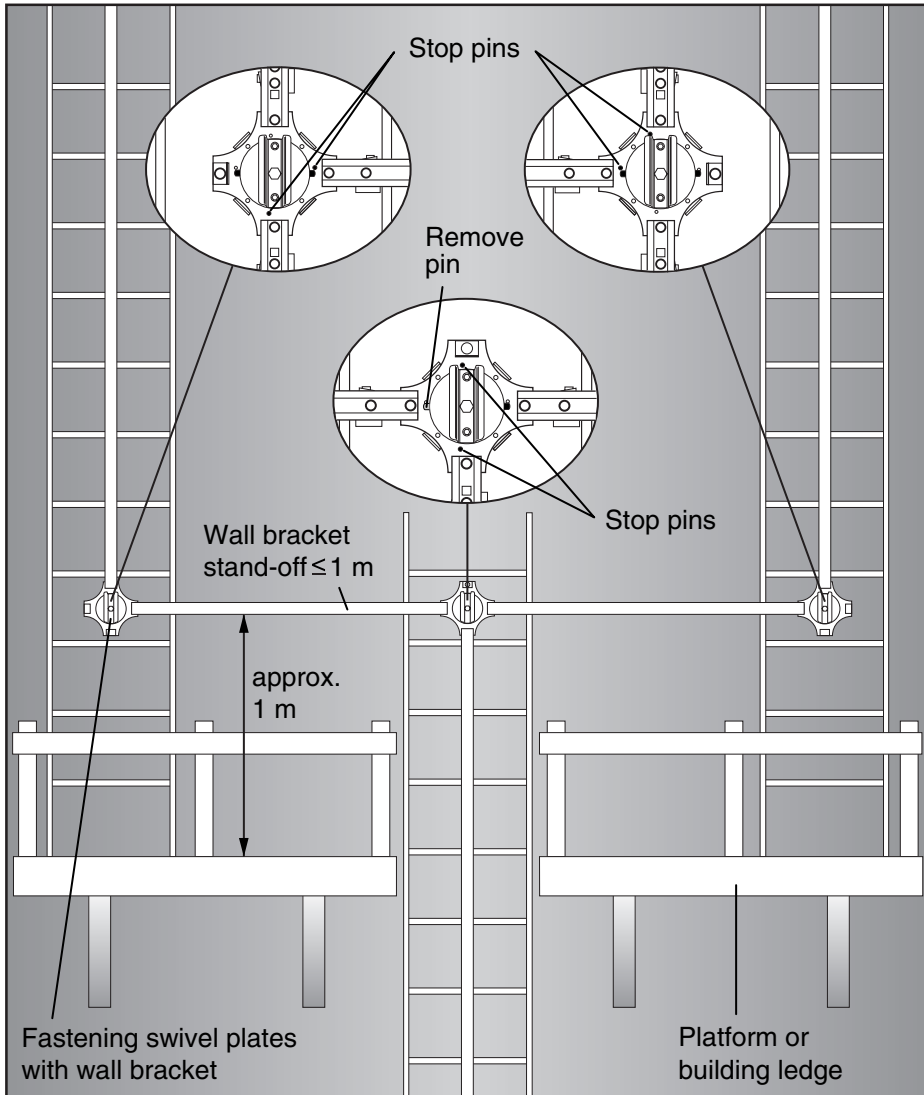

Fig. 1.1 Representation of a total system

3.3.1 Operation of the arrester system

The ZARGES ZAST-type arrester system consists of the arrester rail (1.2/1) and slide mechanism (1.2/2). The safety harness loop (accessory) is hooked into the slide mechanism.

When climbing, the slide mechanism is pulled along in the arrester rail.

In case of a fall, the pawl engages in the cutouts in the arrester rail, so catching the falling person. The energy-absorbing strap element (1.2/3) (part of the slide mechanism) absorbs the energy created during the fall.

According to the results of the EC type test, the arrester has a

max. braking force $F_{\max} = 5.6 \text{ kN}$

and a

catching distance $H = 0.80 \text{ m}$.

The catching effect of the arrester is no longer given within a certain range above the ground. For the ZAST-type arrester system from ZARGES a

hazard zone of 3.0 m

is given, based on the calculations of the performance data and the required free area for holding the person after the fall.

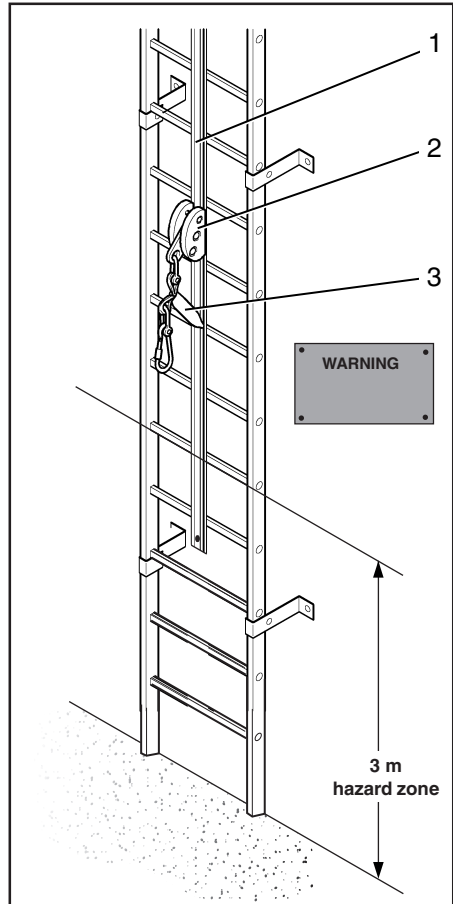

Fig. 1.2 Drawing of the arrester system (not true to scale)



3.3.2 Arrestor rail and connector

The arrestor rails (2/1) are sections available in three different lengths. To prevent damage due to weather and contact corrosion, they are made of galvanized steel or stainless steel.

They can be installed beside or in the centre of ladders or manhole steps.

Two arrestor rails are normally joined with a connector (2/2) (including screws, washers and self-locking nuts) supplied with the arrestor rails.

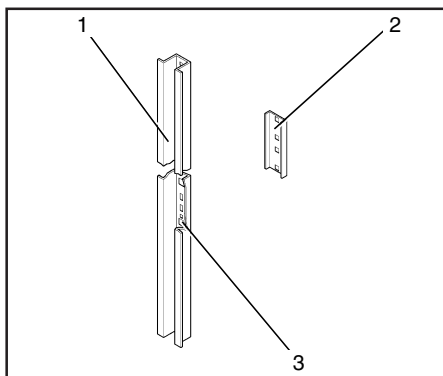

Fig. 2 Arrestor rail

The slide mechanism, which engages in the cutouts (2/3) during a fall and catches the falling person, is mounted on the arrestor rails.

Type \ Length in m	1.40	1.96	2.80
Stainless steel (type A) Order No.	47550	47551	47552
Galvanized steel (type B) Order No.	47530	47531	47532

NOTE Optionally, rails without cutouts are also available for horizontal arrestor rails.

3.3.3 Slide mechanism

The slide mechanism (3) consists of the following components:

- slide (3/1)
- shackle (3/3)
- energy-absorbing strap element (3/4)
- snap hook (3/5) for two-hand operation

The slide is made of aluminium (Order No. 47562 or 47588) or stainless steel end pieces (Order No. 47572). On slides with aluminium end pieces the bearing parts and pawl are also made of stainless steel. The slide is provided with a forced entry, ie one end piece is bevelled (3/2). Only the bevelled end piece can pass the fixed web of the removable and fixed rail stop.

End piece (3.1/6), on the other hand, is round and not bevelled, and it serves as a stop on the rail stop in case the guidance direction is incorrect.

The direction of the arrow on the adhesive label (3.1/7) indicates the slide running direction.

For vertical movement from the bottom up or from the top down, the running direction of the slides must always be upwards (arrow showing up).

For the horizontal movement, the running direction must always be away from the swivel plate to the left or right (arrow showing to the left or right).

The energy-absorbing strap element (3/4) consists of a folded strap made of a synthetic material, which is heat-sealed in a plastic bag.

The slide mechanism belongs to the personal protective equipment.

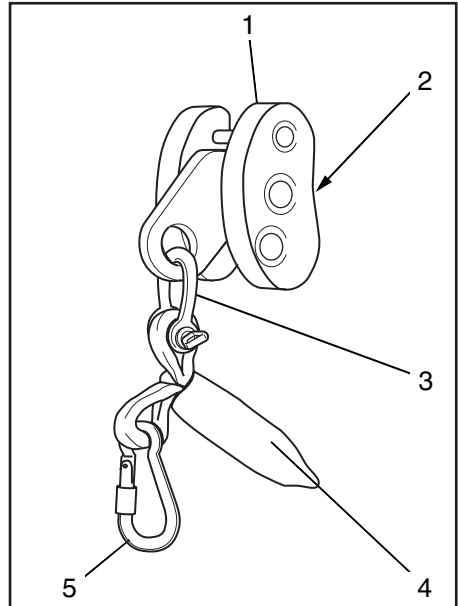

Fig. 3 Slide mechanism, right end piece (2)

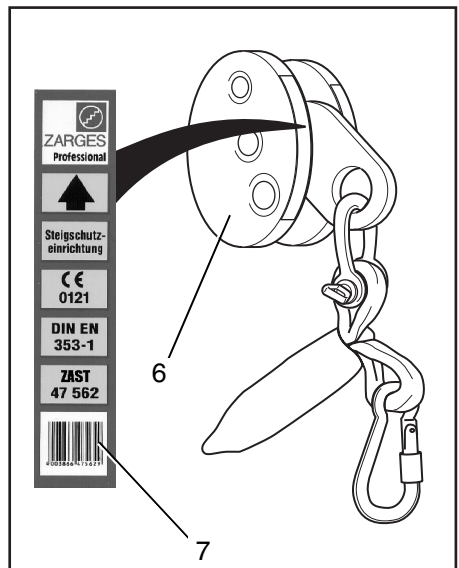

Fig. 3.1 Slide mechanism, left end piece (6)

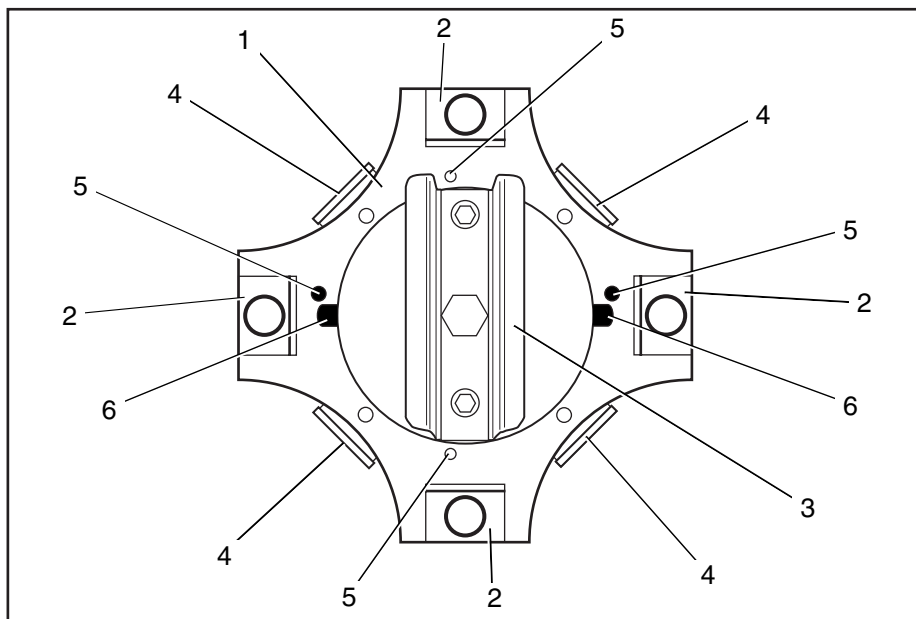

Fig. 4 Swivel plate

3.3.4 Swivel plate

The swivel plate (4) is made of galvanized steel (Order No. 47540) or stainless steel (Order No. 47560). It possesses four entries or exits.

Only a vertical, up-and-down connection or horizontal exits is allowed with the swivel plate.

The rail piece (4/3) can be swivelled on the base plate (4/1) steplessly as far as the adjustable stop. The entries or exits which are not connected are blocked with removable angle brackets (4/2).

The use of 45° exits (4/4) is not allowed.

There are four tapped holes (4/5) in the base plate into which pins acting as stops are screwed, depending on the direction of the iron piece.

The two pins (4/6) in the rotary plate of the rail piece are the stop of the base plate pins.

The adjustment of the base plate pins and of the rotary plate depends on the various applications of the swivel plate, see Section 5.3.



3.3.5 Rail stops

The rail stops are made exclusively of stainless steel. They are used to secure the entry or exit of the arrester system against unintentional pulling out of the slide mechanisms.

There are two types of rail stops:

The fixed rail stop (5/1) (Order No. 47564) and the removable rail stop (5/2) (Order No. 47565).

Another rail stop (5/3), installed directly behind the swivel plate in the horizontal arrester rail, blocks the slide mechanism in the wrong guidance direction.

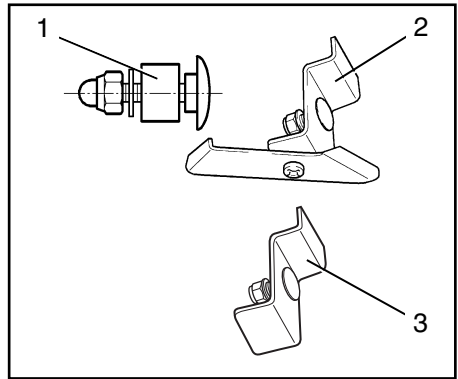

Fig. 5 Rail stops

3.3.6 Rail access extension with pin

The rail access extension (6/1) is made of galvanized steel (Order No. 47541) or stainless steel (Order No. 47561).

With the rail access extension the user can insert the slide mechanism while standing on safe footing, and by installing it on to the pin (6/4) he can safely reach the arrester system. The rail access extension locks automatically in place after being pivoted (arrester rails are in line). The extension is released by depressing the lever (6/2).

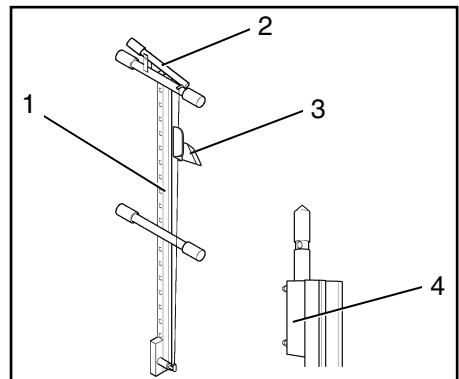

Fig. 6 Rail access extension

A removable rail stop (6/3) at the upper end of the rail access extension facilitates climbing out with the slide mechanism. It also prevents the incorrect insertion of the slide mechanism.

The pin for rail access extension (Order No. 47563/47573) (6/4) is screwed on to the arrester rail or single stile ladder.



3.3.7 Folding rest platform

The folding rest platform (7/1) is screwed to the arrester rail or single stile ladder and can easily be folded down and up with the foot by the user of the arrester system.

It is made of galvanized steel (Order No. 47539) or stainless steel (Order No. 47559).

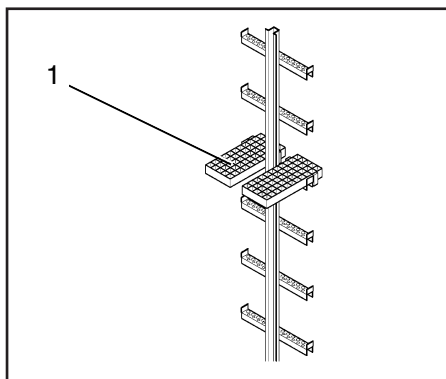

Fig. 7 Folding rest platform (down)

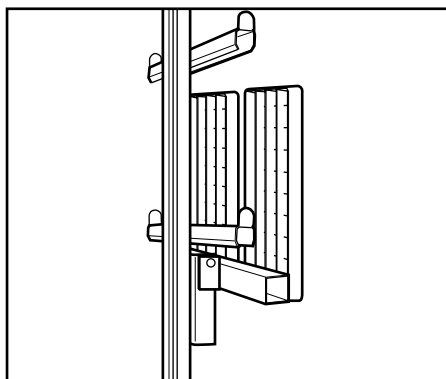

Fig. 7.1 Folding rest platform (up)

3.3.8 Single stile ladder with integrated arrester rail

The single stile ladder (8) is made of galvanized steel or stainless steel.

It is installed on walls or manholes with wall brackets.

The single stile ladder consists of the arrester rail (8/1) and the welded-on perforated rungs (8/2). The perforated rungs are of the anti-slip type due to bossed holes and bordered outer edges.

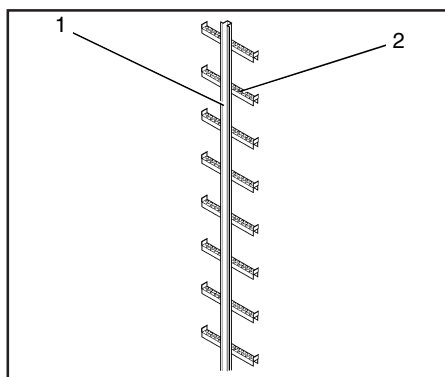

Fig. 8 Single stile ladder

The connection between two single stile ladders is made with a connector as is the case with the arrester rails, see Section 3.3.2.

The slide mechanism, which engages in the cutouts in case of a fall and catches the falling person, is installed on the arrester rail of the single stile ladder.

Type \ Length in m	1.40	1.96	2.80
Stainless steel (type A) Order No.	47553	47554	47555
Galvanized steel (type B) Order No.	47533	47534	47535

3.3.9 Fasteners and wall brackets

The fasteners for the various applications are shown below.

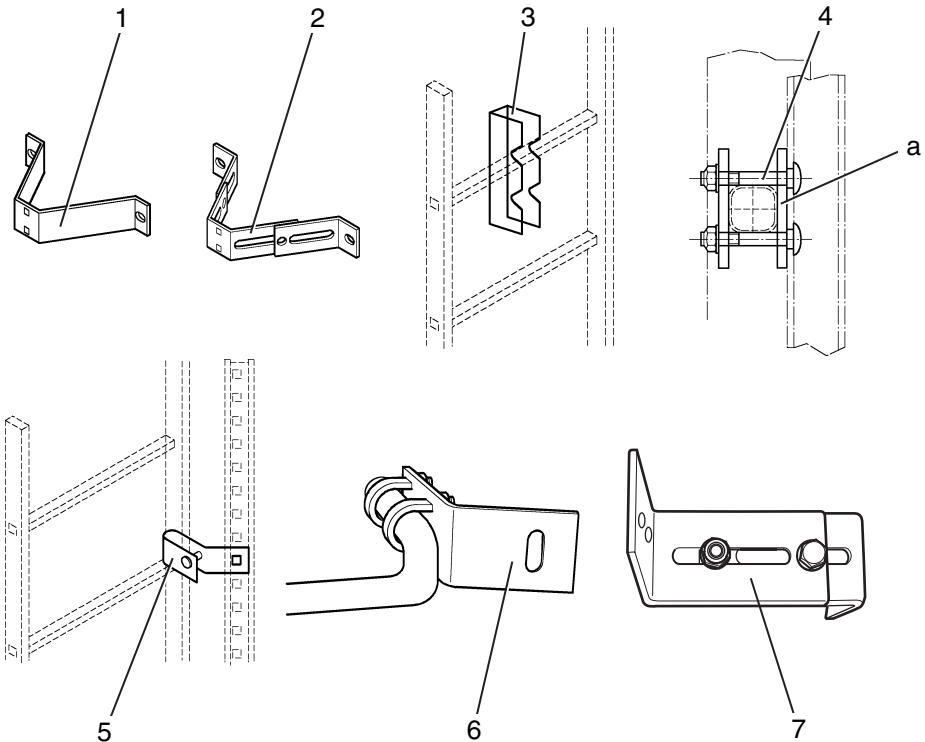

Fig. 9 Fasteners

- | | |
|--|---|
| <ul style="list-style-type: none"> 1 Wall bracket, fixed 2 Wall bracket, adjustable 3 Arrester system bracket for fitting on rung ladders (rung spacing ≤ 280 mm) 4 Rung bracket for arrester system a Spacer, 10 or 20 mm thick.
Only used as compensation when mounting a swivel plate. | <ul style="list-style-type: none"> 5 Bracket for arrester system mounted beside the stile 6 Bracket for arrester system for single-row manhole steps (DIN V 19555) 7 Wall bracket for swivel plate |
|--|---|



The wall brackets (9/1 and 2) are used for fitting the single stile ladder or the arrester rail on the wall or in a manhole if two rows of step irons are installed. The adjustable wall bracket can be adjusted from 120 to 180 mm.

Wall bracket, fixed

- Galvanized steel, Order No. 47537
- Stainless steel, Order No. 47557

Wall bracket, adjustable

- Galvanized steel, Order No. 47538
- Stainless steel, Order No. 47558

Bracket for fitting an arrester system on rung ladders

This bracket (9/3) is used to mount arrester rails on ladders from other manufacturers if the rung spacing is not exactly 280 mm.

- Galvanized steel, Order No. 47543
- Stainless steel, Order No. 47566

Bracket for fitting an arrester system on ladder rungs

This bracket (9/4) is used to fit arrester rails at the centre of rung ladders.

- Stainless steel, Order No. 47556

Bracket for arrester system fitted beside the stile

This bracket (9/5) is used to fit arrester rails beside rung ladders.

- Stainless steel, stile size 50 x 20 mm, Order No. 47545
- Stainless steel, stile size 58 x 25 mm, Order No. 47546

Bracket for arrester system beside single-row manhole steps (DIN 19555)

This bracket (9/6) is used to mount arrester rails beside single-row manhole steps conforming to DIN 19555.

- Stainless steel, Form A, Order No. 47547
- Stainless steel, Form B, Order No. 47548

Wall bracket for swivel plate

The wall bracket (9/7) is used to mount the swivel plate on the wall.

- Galvanized steel, Order No. 47540
- Stainless steel, Order No. 47560



ZARGES

3.3.10 Accessories

The safety harness (9.1) made in accordance with EN 361 is available as an accessory. The harness has an arrester loop at the front.

Order No. 47524

ATTENTION Only the arrester loop (9.1/1) may be used to attach the slide mechanism.

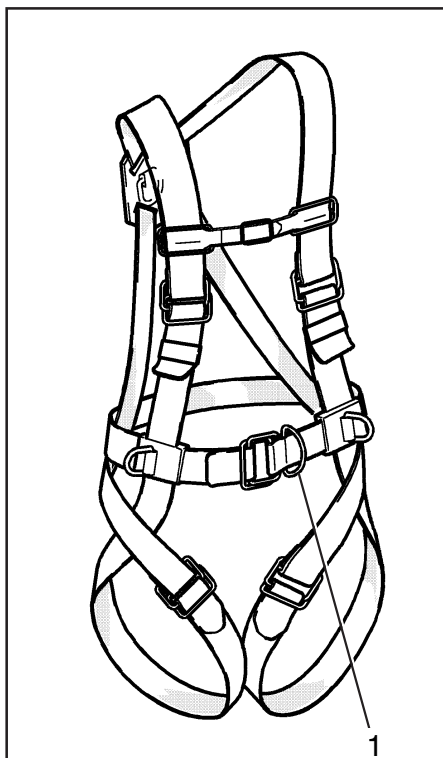

Fig. 9.1 Safety harness

4 INSTALLATION

4.1 Safety rules

- All safety rules in section 2 must be observed and adhered to.
- ZARGES arrester systems may only be installed and operated with genuine ZARGES components. The combination with components from other manufacturers can reduce safety and is not allowed.



- Before the installation of the arrester rails on existing ladder systems or single-row manhole steps, they must be inspected by an expert for proper condition. The ladders must be in line and plumb.
The arrester system may only be installed on faultless ladder systems and manhole steps conforming to legal requirements.
It must first be checked if the existing ladder system or the manhole steps can bear an impact force of 6 kN. If this is not the case, the arrester system may not be installed and taken into operation.
On existing ladder systems the rung spacing should not exceed 280 mm; if necessary, use the bracket with the Order No. 47543 or 47566 (9/3). On rung ladders with plastic caps at the ends of the ladder, remove the caps at the feet.
If the arrester system is retrofitted on an existing ladder system, the arrester rail must be fastened on every fifth rung.
- Only genuine ZARGES screws may be used for screwed joints. The carriage bolts possess a square neck sized specifically for the arrester rail. On commercial carriage bolts the square neck is smaller.
Always use self-locking nuts for screwed joints.
Always tighten the screwed joints using a torque wrench.
- Before the installation of the wall bracket, check the wall or manhole for an even and plumb surface; use adjustable wall brackets, if necessary.
- The wall bracket must be fastened with plugs approved by building authorities. The installation firm responsible for the installation must inspect the walls exactly. In case of doubt, contact an expert for rough plaster planning or a specialist at the plug manufacturer's or at Zarges.
- The wall brackets for single stile ladders must be fitted with an interval of 1.0 m.
- The fastening elements (eg wall brackets) must be fitted at an interval of ≤ 1.68 m (German Mail recommends an interval of ≤ 1.12 m). If the interval is less (eg with arrester rails 1.40 long) than 1.68 m, at least two fastening elements must be used.



- The arrester rails on ladders (at the side or in the centre) must be installed at intervals of ≤ 1.68 m on the ladder (German Mail recommends an interval of ≤ 1.12 m). If the interval is less than 1.68 m, at least two mounting points must be used.
- On ladders, the arrester rails may only be mounted in the centre of the ladder if the clear internal space between the ladder stiles is 400 mm. If the clear internal space is less than 400 mm, the arrester rail must be installed at the side. On manhole steps acc. to DIN V 19555, arrester rails may only be installed at the side as the ZH 1/604 specifies a step area of 85 mm at each place.
- The arrester rails for manhole steps acc. to DIN 19555 (lateral) must be fastened at every third step iron. One bracket must be fitted to the top and bottom step iron.
- In the case of two-row manhole steps acc. to DIN 1212/1211, arrester rails are only mounted in between if the interval between the step irons is ≥ 90 mm. The installation is the same as for wall brackets.
- The arrester rails must be joined with connectors (included in shipment) so that the ends of the arrester rails are flush.
- The top end of the arrester system must be provided with a pivoting rail access extension so that the user can enter and exit the arrester system from safe footing.
- The top end of the arrester rail must be chosen so that the rail access extension projects at least 1 m over the exit.
- In manholes, the arrester rail with the bolted pin must be terminated so that it does not contact the cover or catch pan.
- The arrester rails must be provided with a rail stop at the top, bottom and horizontal ends.
- Arrester systems with a length of over 10 m must be provided with a rest platform every 10 m.
- If the arrester system is mounted horizontally, wall brackets must be installed every ≤ 1.00 m.
- Aluminium arrester rails may not be used for a horizontal arrester system.

4.2 Installation of arrester system in the centre of ladder rungs

- It is recommended to install the lower end of the arrester rail 0.80 m to 1.00 m over the standing area in order to ensure a comfortable entry for the user.
- If a swivel plate is installed in the arrester system, plan the installation of the arrester rail so that an arrester rail ends before the swivel plate. The arrester rails mounted directly before and behind the swivel plate must be shortened, see Section 4.8.
- If a swivel plate is used, a 10mm-thick stainless steel plate (10/5) must be installed between the arrester rail and stile if the stile dimension is 50 x 20 mm and a stainless steel plate (10/5) 20 mm thick if the stile dimension is 58 x 25 mm.

If stainless steel plates (10/5) are installed, longer screws must be used depending on the thickness of the plate.

The stainless steel plates and the appropriate screws are available from ZARGES-Steigtechnik.

- It is recommended to carry out the installation from the bottom up on buildings and from the top down in manholes.

CAUTION During installation, the installer must be protected against falling with the appropriate measures.

1. Screw the arrester rail (10/2) with plate (10/1) and carriage bolts (10/3) to the centre of the ladder rung (10/4). Do not tighten the screws yet.

ATTENTION Observe the specified bracket intervals.

2. Install all brackets for the first arrester rail as described in work step 1.

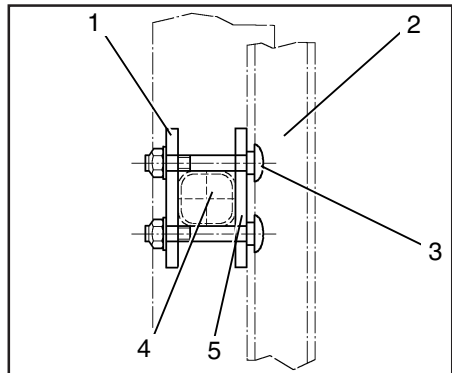

Fig. 10 Arrester rail bracket on the ladder rung



3. Align the arrester rail plumb and centred, tighten the fastening nuts of all brackets to a torque of 17 Nm.
4. Position the second arrester rail flush and in line with the first arrester rail and install as described in work steps 1 and 2.
5. Join both arrester rails (11/2 and 3) with the connector (11/1). To do this, install the connector on the arrester rail from behind as shown in Fig. 11.

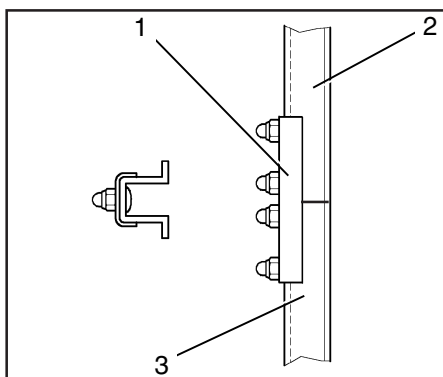

Fig. 11 Connection of two arrester rails

6. For the installation of further arrester rails repeat work steps 1 to 5.
7. Install rail stops at the top and bottom of the arrester system, see Section 4.10.
8. Install the pin as described in Section 4.9.
9. Perform the post-installation activities, see Section 4.12.

4.3 Installation of arrester system laterally on the stile

- The arrester system can be installed on the left or right stile.
- It is recommended to install the lower end of the arrester rail 0.80 m to 1.00 m over the standing area in order to ensure a comfortable entry for the user.
- A swivel plate can not be fitted in the arrester system with this type of installation.
- It is recommended to carry out the installation from the bottom up on buildings and from the top down in manholes.
- The selection of the bracket depends on the size of the ladder stile.



CAUTION During installation, the installer must be protected against falling with appropriate measures.

1. Install the brackets (12/3) for the first arrester rail (12/2) on the stiles (12/1) above the rungs (12/4). Do not tighten the screws yet.

ATTENTION Observe the specified bracket intervals.

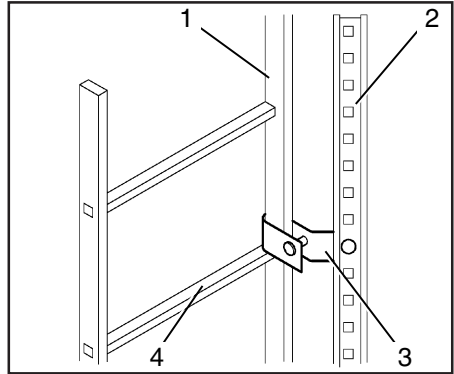

Fig. 12 Installation beside the stile

2. Fasten the arrester rail on the brackets. Do not tighten the screws yet.
3. Align the arrester rail and brackets plumb and at the same interval to the stile, and tighten the fastening nuts on all brackets to a torque of 17 Nm. Torque the nuts on the arrester rail to 17 Nm.
4. Install the brackets for the second arrester rail as described in work step 1.
5. Position the second arrester rail flush and in line with the first arrester rail and install as described in work steps 2 and 3.
6. Join both arrester rails (11/2 and 3) with a connector (11/1). To do this, install the connector on the arrester rail from behind as shown in Fig. 11.
7. For the installation of further arrester rails, perform work steps 1 to 6.
8. Install rail stops at the top and bottom of the arrester system, see Section 4.10.
9. Install the pin for rail access extension as described in Section 4.9.
10. Perform the post-installation activities, see Section 4.12.



4.4 Installation of arrester system on single-row manhole steps

- It is recommended to install the lower end of the arrester rail 0.80 to 1.00 m above the standing area in order to ensure a comfortable entry for the user.
- A swivel plate can not be fitted in the arrester system with this type of installation.
- The bracket type to be used depends on the step irons (form A or B).
- The brackets must be installed on the step irons so that the slide mechanism can slide past the step irons without making contact.

CAUTION During installation, the installer must be protected against falling with the appropriate measures.

1. Install the brackets (13/2) for the first arrester rail with both clamps (13/1) on the step irons (13/4). Do not tighten the screws yet.

ATTENTION Install the brackets at intervals of 0.75 m.

2. Screw the arrester rail (13/3) on to the brackets. Do not tighten the screws yet.
3. Align the arrester rail and brackets plumb and at the same interval to the step irons, and tighten the fastening nuts on all brackets to a torque of 17 Nm. Torque the nuts on the arrester rail to 17 Nm.

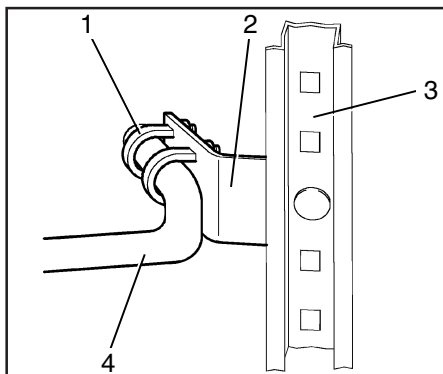

Fig. 13 Installation on single-row manhole steps

4. Install the brackets for the second arrester rail as described in work step 1.

5. Position the second arrester rail flush and in line with the first arrester rail and install as described in work steps 2 and 3.
6. Join both arrester rails (11/2 and 3) with a connector (11/1). To do this, install the connector on the arrester rail from behind as shown in Fig. 11.
7. For the installation of further arrester rails, perform work steps 1 to 6.
8. Install rail stops at the top and bottom of the arrester system, see Section 4.10.
9. Install the pin for the rail access extension as described in Section 4.9.
10. Perform the post-installation activities, see Section 4.12.

4.5 Installation of arrester system with two-row manhole steps

- It is recommended to install the lower end of the arrester rail 0.80 m to 1.00 m over the standing area in order to ensure a comfortable entry for the user.

CAUTION During installation, the installer must be protected against falling with the appropriate measures.

1. Install the wall brackets (14/2) for the first arrester rail on the wall (14/1) with dowels in the centre between the step irons (14/4) and secure with two fastening screws. Be sure the brackets are plumb and in line; if necessary, use adjustable wall brackets.

ATTENTION Observe the specified bracket intervals.

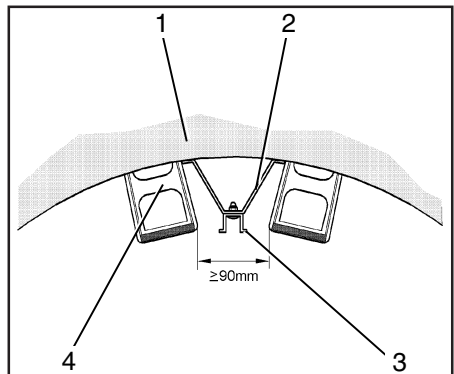

Fig. 14 Installation with two-row manhole steps



ZARGES

2. Screw the arrester rail (14/3) on the wall brackets with two carriage bolts. Do not tighten the screws yet.
3. Make the arrester rail plumb, tighten the fastening nuts on the arrester rail to a torque of 17 Nm.
4. Install the wall brackets for the second arrester rail as described in work step 1.
5. Position the second arrester rail flush and in line with the first arrester rail and install as described in work steps 2 and 3.
6. Join both arrester rails (11/2 and 3) with a connector (11/1). To do this, install the connector on the arrester rail from behind as shown in Fig. 11.
7. For the installation of further arrester rails, perform work steps 1 to 6.
8. Install rail stops at the top and bottom of the arrester system, see Section 4.10.
9. Install the pin for the rail access extension as described in Section 4.9.
10. Perform the post-installation activities, see Section 4.12.

4.6 Installation of single stile ladders with integrated arrester rail

- The first and last ladder rungs must be max. 300 mm over the standing area or below the top edge.
- If a swivel plate is installed in the arrester system, plan the installation of the single stile ladder so that a single stile ladder ends before the swivel plate. The arrester rails of the single stile ladder mounted directly before and behind the swivel plate must be shortened, see Section 4.8.
- It is recommended to carry out the installation from the bottom up on buildings and from the top down in manholes.

CAUTION During installation, the installer must be protected against falling with the appropriate measures.

1. Install the wall brackets (15/2) for the first single stile ladder on the wall with dowels and fasten with two screws. Be sure the brackets are plumb and in line; if necessary, use adjustable wall brackets.

ATTENTION Observe the specified wall bracket intervals.

2. Screw the single stile ladder (15/1) on the wall bracket with two carriage bolts. Do not tighten the screws yet.

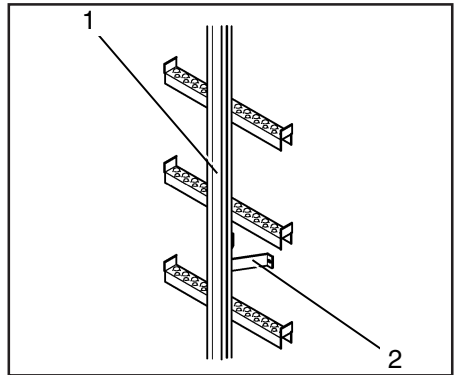

Fig. 15 Installation of single stile ladder

3. Make the single stile ladder plumb, tighten the fastening nuts to a torque of 17 Nm.
4. Install the wall brackets for the second arrester rail as described in work step 1.
5. Position the second single stile ladder flush and in line with the first and install as described in work steps 2 and 3.
6. Join both arrester rails of the single stile ladders (11/2 and 3) with a connector (11/1). To do this, install the connector on the arrester rail from behind as shown in Fig. 11.
7. For the installation of further single stile ladders, perform work steps 1 to 6.
8. Install rail stops on the arrester system at the top, bottom and side, see Section 4.10.
9. Install the pin for the rail access extension as described in Section 4.9.
10. Perform the post-installation activities, see Section 4.12.



4.7 Installation of folding rest platform

- The folding rest platforms are fitted after the installation of the arrester rails or the single stile ladder.

ATTENTION Keep the specified intervals of the folding rest platforms.

1. Position the rest platform (16) on the arrester rail (16/1) from behind so that the platform (16/2) rests on the rung (16/4) when folded down.
2. Always fit the rest platform with two fastening screws (16/3) and torque them to 17 Nm.

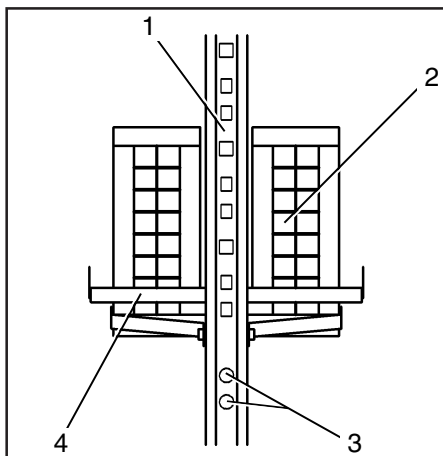

Fig. 16 Installation of rest platform

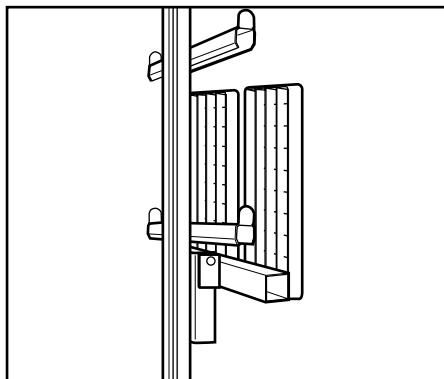

Fig. 16.1 Installation of rest platform

4.8 Installation of swivel plates

NOTE The installation of the swivel plate must be carried out exactly as described.

- The shortening of the arrester rail directly before and behind the swivel plate is necessary in order to observe the specified rung spacing of 280 mm.

1. Saw approx. 80 mm off the arrester rail as shown in Fig. 17.

2. If a galvanized steel arrester rail or single stile ladder is used, cover the cutting edge with a suitable anticorrosion paint.

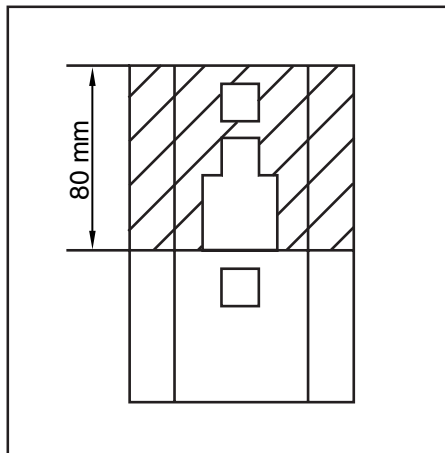

Fig. 17 Shortening the arrester rail

3. Align the swivel plate so that the rail piece (18/3) is in the vertical position and both pins (18/2) are below the two pins (18/1) of the base plate.

ATTENTION Do not remove the angle brackets at the unused exits (18/4).

4. Remove the angle brackets (18/4) for the desired entry or exit.

5. Fasten the swivel plate (18) in the centre between the rungs on the upper or lower vertical arrester rail (18/5 or 6) with screws. Do not tighten the screws yet.

6. Install the wall bracket for the swivel plate on the wall with dowels, see Section 4.11, and secure with two fastening screws.

7. Screw the second vertical arrester rail to the swivel plate. Do not tighten the screws yet.

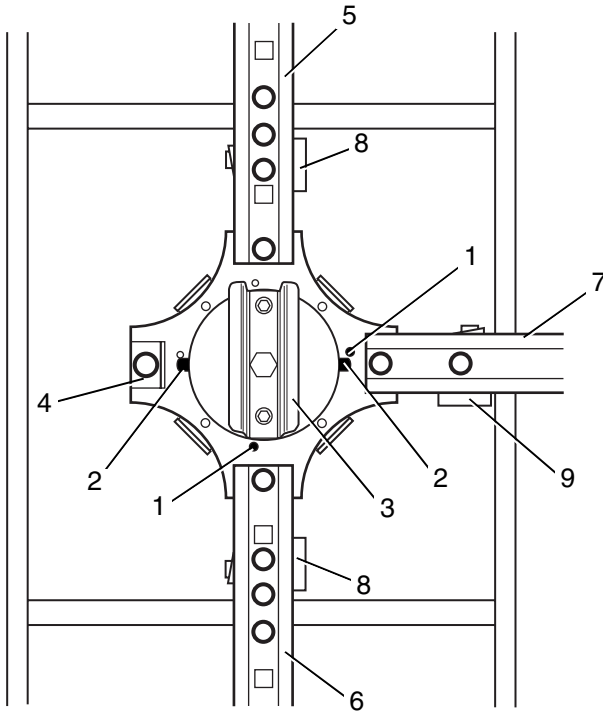

Fig. 18 Installation of the swivel plate (exit to the right)

8. Align the swivel plate plumb to the vertical arrester rail so that the rotary rail piece (18/3) on the rotary plate is in line with the arrester rails.
9. Screw the horizontal arrester rail (18/7) to the swivel plate and to the previously mounted wall brackets. Do not tighten the screws yet.
11. Unscrew both pins (18/1) from the base plate and rail piece (18/3) for free movement in the arrester rails, aligning the arrester rails if necessary.
12. Tighten all fastening screws on the swivel plate and the vertical and horizontal arrester rails to a torque of 17 Nm.
13. Turn the rail piece to its initial position and screw the two pins (18/1) back in.

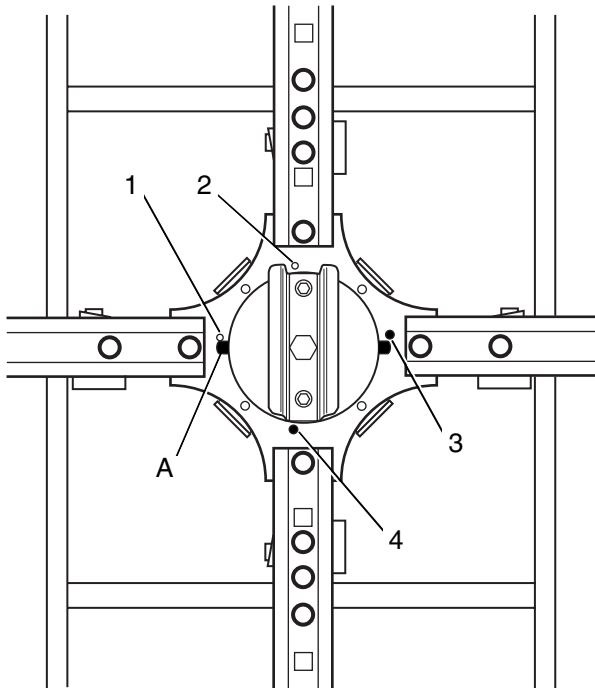

Fig. 18.1 Installation of the swivel plate (exit to the left/right)

ATTENTION If the swivel plate is installed with the exit to the left, the pins must be positioned as shown in Fig. 18.1, items 1 and 2.

If the swivel plate is installed with the exit to the right, the pins must be positioned as shown in Fig. 18, item 1.

If the swivel plate is installed with the exit to the left and right, the pins must be positioned as shown in Fig. 18.1, items 2 and 4. Remove pin (18.1/A).

If the swivel plate is installed with the exit to the left, right and upwards, the pins must be positioned as shown in Fig. 18.1, items 2 and 4. Remove pin (18.1/A).



14. Install the removable rail stops (18/8) on the vertical arrester rails above and below the swivel plate, see Section 4.10.

The rail stop above the swivel plate must be installed so that the slide mechanism is prevented from moving downwards.

The rail stop below the swivel plate must be installed so that the slide mechanism is prevented from moving upwards.

15. Install a fixed rail stop at the ends of the left and/or right horizontal arrester rails, see Section 4.10.

16. Install the rail stop (18/9) in the horizontal arrester rails behind the swivel plate.

Install the horizontal rail stops so that the slide mechanism can always slide to the right or left in direction of the swivel plate, see Section 4.10.

17. Perform the post-installation activities, see Section 4.12.

4.9 Installation of the pin for rail access extension (Order No. 47563/47573)

1. Screw the pin (19/3) from behind to the top edge of the arrester rail (19/2) so that the base body is flush with the top edge of the arrester rail.

ATTENTION The transverse hole (19/1) in the journal must face to the left if viewed from the front (19). If the hole faces to the right, the rail access extension lock can not engage.

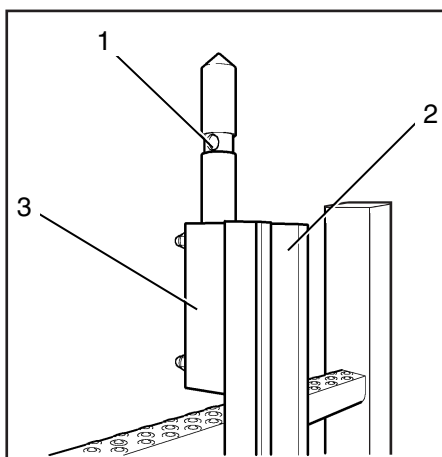

Fig. 19 Pin for rail access extension



NOTE For the installation of the pin (Order No. 47573), the rail access extension must be secured with the supplied hex head screw and washer. The hex head screw must be coated with a very strong screw glue (eg Loctite 765) and screwed through the rail access extension into the pin.

4.10 Installation of the rail stops

NOTE If a fixed rail stop is installed at the lower end of the arrester system, the slide mechanism can not be removed from the arrester rail. For this reason it is recommended to install a removable rail stop at the lower end as well.

ATTENTION On horizontal arrester rails, however, always install a fixed rail stop on each end.

Installation of the fixed rail stop

1. Insert the carriage bolt (20/2) through the arrester rail (20/1) from behind.
2. Slide the spacer (20/3) on the carriage bolt so that the countersink faces **away** from the arrester rail.
3. Slide a washer (20/4) on the carriage bolt and into the countersink.
4. Screw on the cap nut (20/5) and torque the nut to 17 Nm.

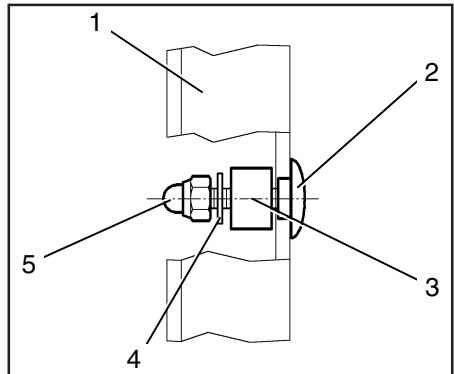

Fig. 20 Installation of the fixed rail stop



Installation of the rail stop behind the swivel plate (horizontal exit to the right, left)

1. Install the rail stop bracket (20.1/1) with a carriage bolt on the arrester rail (20.1/2) and torque the fastening nut to 17 Nm.

ATTENTION Install the bracket so that the fixed web (20.1/3) on the right arrester rail (viewed from the front) is at the bottom.

On the left arrester, however, the fixed web (20.1/4) should be at the top.

This will determine the direction of pull of the slide mechanism to the right/left away from the swivel plate.

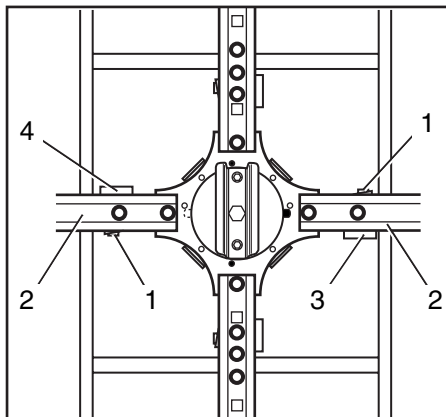

Fig. 20.1 Installation of a rail stop (horizontal exit)

Installation of the removable rail stop (top exit)

1. Install the rail stop bracket (21/1) on the arrester rail (21/2) from behind with a carriage bolt and torque the fastening nut to 17 Nm.

ATTENTION Fasten the bracket so that the take-up for the pawl (21/4) faces left when looking on the arrester rail from the front. The take-up for the pawl must show to the rear.

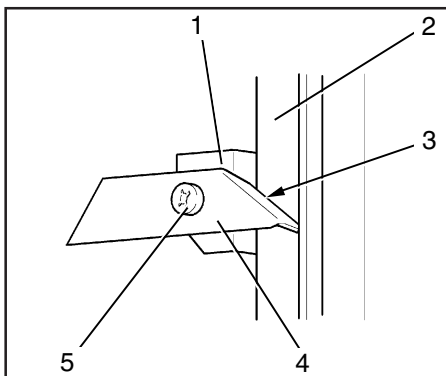

Fig. 21 Installation of a removable rail stop (top exit)

2. Install the pawl on the bracket with the Philips screw (21/5) as shown in Fig. 21. The bevelled area (21/3) must face the arrester rail.
3. Tighten the Philips screw so that the pawl is not loose, but moves easily nevertheless.

Installation of the removable rail stop (lower exit)

1. Install the rail stop bracket (22/1) on the arrester rail (22/2) from behind with carriage bolt and torque the fastening nut to 17 Nm.

ATTENTION Fasten the bracket so that the take-up for the pawl (22/4) faces left when looking on the arrester rail from the front. The take-up for the pawl must show to the rear.

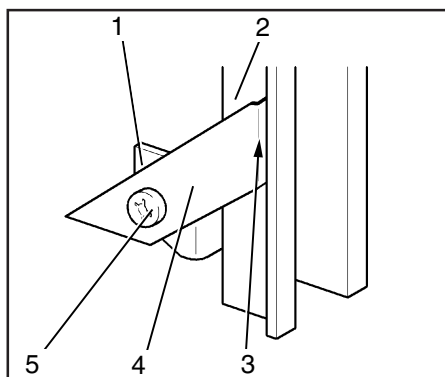

Fig. 22 Installation of removable rail stop (lower exit)

2. Install the pawl on the bracket with the Philips screw (22/5) as shown in Fig. 22. The bevelled area (22/3) must face the arrester rail.
3. Tighten the Philips screw so that the pawl is not loose, but moves easily nevertheless.



4.11 Plugs

Wall brackets fastened in B-25 concrete with plugs must be installed with at least 2 fasteners, because the ladder and arrester system must bear an impact force of 5 kN.

For other than B-25 concrete walls, contact an expert for rough plaster planning or a specialist at the plug manufacturer or ZARGES-Steigtechnik for details.

The installation company is responsible for the work.

Only plugs approved by the building authorities may be used.

4.12 Post-installation activities

Perform the following checks after installation and before the initial use of the arrester system:

- Are the arrester rails or single stile ladders in line?
- Are all arrester rails or single stile ladders screwed together with connectors?
- Are all specified brackets installed and the screwed joints tightened to the correct torque?
- Are all the specified rail stops installed and operable?
- Are all specified folding rest platforms installed and operable?
- Are all swivel plates installed correctly and operable? Do the rotary plates **only** turn in the specified directions?
- Are all surfaces undamaged, especially on the galvanized steel components? Touch up damaged surfaces with a suitable anticorrosion paint.

5 OPERATION OF THE ARRESTER SYSTEM

5.1 Safety rules and precautions

- The slide mechanism with shackle, energy-absorbing strap element and snap hooks belong to the personal protective equipment of the user, who is also responsible for it and for its proper operation.
- The arrester system may only be entered from above with a rail access extension.
- The user must make a visual inspection of the arrester system before entering it. If deficiencies are detected during the visual inspection, they must be eliminated by skilled personnel before use.
- Unauthorised changes on components of the arrester system are not allowed and will void the guarantee and liability.
- Only arrester systems may be used which are inspected regularly within the legally specified inspection intervals.
- The user must wear a safety harness acc. to EN 361 with an arrester loop. The putting-on and the attachment of the safety harness to the slide mechanism must be in accordance with the operating instructions supplied with the safety harness.
- The components stressed during a fall must be taken out of use, sent to the manufacturer for inspection and, if necessary, repaired. Do not use the slide mechanisms with a pulled-out energy-absorbing strap element.
- The user may only enter the arrester system if he is physically healthy and physically capable (no alcohol, no drugs, no medicine) of climbing.
- See Section 6 for storage and cleaning.
- Only ZARGES components may be used in a ZARGES arrester system. Do not mix components with parts from other manufacturers.
- When entering the arrester system, do not carry a load in your hands. Only minimal loads may be attached to the eyelets on the safety harness.



- The safety harness arrester loop must be hooked directly (ie without a rope, etc) into the slide mechanism.
- If the slide mechanism remains on the arrester rail after use, it must be secured against unauthorised use. In this case, ensure that it is protected against unfavourable weather influences (rain, sun, etc).
- If the energy-absorbing strap element has become wet or moist through use or cleaning, it may **only** be dried in a natural way and not through the direct rays of the sun, fire or other sources of heat.
- The inspection intervals must be shortened if the energy-absorbing strap element is exposed to extreme temperatur fluctuations.

PRECAUTIONS

- The snap hook may only be attached to the centre safety harness arrester loop. Do not hook it in eyelets at the side, front or in the hip or breast area of the safety harness.
- Do not use holding straps, seat belts or older safety harnesses of form B, which only partially surround the body, for climbing.
- Only climb with the safety harness closed, ie with a properly closed snap hook.
- Observe the specifications on page 15, especially the fact that the arrester system offers no protection below a height of 3 m (measured from the ground). The owner of the installation must affix the appropriate warning sign on the site, which informs the user of this safety distance, see page 15.
- The protective effect is also not given if a permanent horizontal force acts on the arrester during climbing. This means that the user may not descend or ascend without using his hands.
- If doubts arise about the safe condition of the installation, it must be inspected by an expert. A system stressed by a fall must be replaced, the sliding mechanism in any case. The rail system must be inspected for damage.

5.2 Entering and exiting the arrester system

Entry from above

1. While standing on a safe footing, fit the rail access extension (23/2) on the mounting pin installed on the arrester rail (23/4).
2. Rotate the rail access extension so that the arrester rail part points to the standing place.
3. Insert the slide mechanism into the rail access extension so that the bevelled end piece can slide past the angle bracket of the removable rail stop (23/1).
4. Hook the snap hook on the slide mechanism to the safety harness arrester loop and secure the snap hook by turning the knurled nut.
5. Step from the safe footing on to the ladder or the step irons while also rotating the rail access extension until it is in line with the arrester rail and engages in the pin.

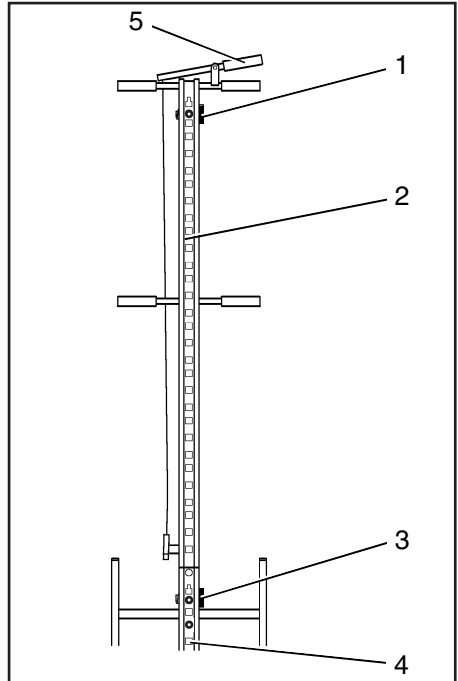

Fig. 23 Installation of the rail access extension

Exiting at the top

- The rail access extension (23/2) is still fitted on the mounting pin.
1. Climb as far as the rail stop (23/3) of the top arrester rail on the ladder or the step irons and do not open the rail stop (23/3).
 2. Check if the rail access extension (23/2) is engaged on the pin.
 3. Open the rail stop (23/3) and guide the slide mechanism on to the rail access extension (23/2).



4. Step from the ladder or the step irons on the safe footing while depressing the release (23/5) on the rail access extension and rotating the rail access extension as well.
5. Detach the snap hook on the slide mechanism from the safety harness arrester loop.
6. Remove the slide mechanism from the rail access extension by opening the rail stop (23/1).
7. Remove the rail access extension from the mounting pin.

Entry from below

1. Insert the slide mechanism at the lower end of the arrester rail so that the bevelled end piece can slide past the angle bracket on the rail stop. (Guiding direction of the sliding mechanism is up, see adhesive label.)

NOTE If the slide mechanism is still on the arrester rail (eg with a fixed rail stop), skip work step 1.

2. Attach the snap hook on the slide mechanism to the safety harness arrester loop and secure the snap hook by turning the knurled nut.

Exiting downwards

1. Detach the snap hook on the slide mechanism from the safety harness arrester loop.
2. Open the removable rail stop at the bottom and lead the slide mechanism down out of the arrester rail.

NOTE Skip this work step if a fixed rail stop is installed at the end so that the slide mechanism stays on the arrester rail. Secure the slide mechanism against unauthorised use.

5.3 Using the swivel plate vertically and horizontally to the left

The basic vertical position of the swivel plate, see Section 4.8, point 3, is the point of departure for the following instructions.

ATTENTION Be sure the pins are screwed in like items 2 and 3 in Fig. 24.

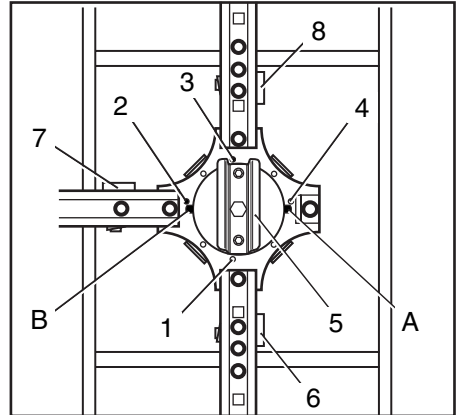

Fig. 24 Swivel plate

1. **Moving up:**
2. Guide the slide mechanism as far as the removable rail stop (24/6). The upward movement is blocked.
3. Open the removable rail stop (24/6) and slide the slide mechanism through the swivel plate up through the rail stop (24/8). The upward movement in the rail stop (24/8) is not blocked.
4. **Moving down:**
5. Guide the slide mechanism as far as the removable rail stop (24/8). The downward movement is blocked.
6. Open the rail stop (24/8) and guide the slide mechanism down through the swivel plate and through the removable rail stop (24/6). The downward movement in the rail stop (24/6) is not blocked.
7. **Going left when coming from above or below:**
8. Guide the slide mechanism up or down into the swivel plate, see points 2 and 3 or 5 and 6.
9. Turn the rail piece (24/5) anticlockwise from the vertical position to the left horizontal direction as far as the pin in the drilled hole (24/3).
10. Guide the slide mechanism to the left over the rail stop (24/7).
11. **Going up or down when coming from the left:**
12. Guide the slide mechanism from the left through the rail stop (24/7) into the rail piece of the swivel plate.
13. Turn the rail piece (24/5) clockwise from the horizontal position to the vertical as far as the pin (24/2).
14. Move the slide mechanism up or down, see point 1. or 4.



5.4 Using the swivel plate vertically and horizontally to the right

The basic vertical position of the swivel plate, see Section 4.8, point 3, is the starting point for the following instructions.

ATTENTION Be sure the pins are screwed in like items 1 and 4 in Fig. 24.1.

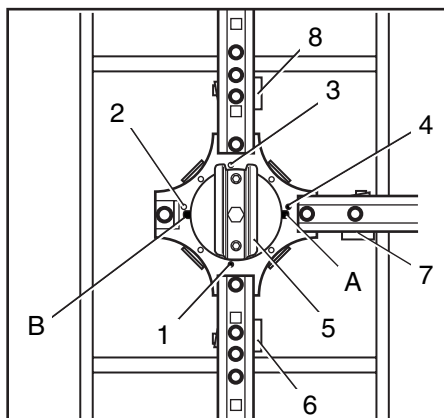

Fig. 24.1 Swivel plate

- 1. Moving up:**
2. Guide the slide mechanism as far as the removable rail stop (24.1/6). The upward movement is blocked.
3. Open the removable rail stop (24.1/6) and slide the slide mechanism through the swivel plate up through the removable rail stop (24.1/8). The upward movement in the rail stop (24.1/8) is not blocked.
- 4. Moving down:**
5. Guide the slide mechanism as far as the removable rail stop (24.1/8). The downward movement is blocked.
6. Open the rail stop (24.1/8) and guide the slide mechanism down through the swivel plate and through the removable rail stop (24.1/6). The downward movement in the rail stop (24.1/6) is not blocked.
- 7. Going right when coming from above or below:**
8. Guide the slide mechanism up or down into the swivel plate, see points 2 and 3 or 5 and 6.
9. Turn the rail piece (24.1/5) clockwise from the vertical position to the right horizontal direction as far as the pin in the drilled hole (24.1/1).
10. Guide the slide mechanism to the right over the rail stop (24.1/7).
- 11. Going up or down when coming from the right:**
12. Guide the slide mechanism from the right through the rail stop (24.1/7) into the rail piece of the swivel plate.
13. Turn the rail piece (24.1/5) anticlockwise from the horizontal position to the vertical as far as the pin (24.1/4).
14. Move the slide mechanism up or down, see point 1. or 4.

5.5 Using the swivel plate vertically and horizontally

The basic vertical position of the swivel plate, see Section 4.8, point 3, is the starting point for the following instructions.

ATTENTION Be sure the pins are screwed in like items 1 and 3 in Fig. 24.2. The pin (24.2/B) must be removed.

1. Moving up:

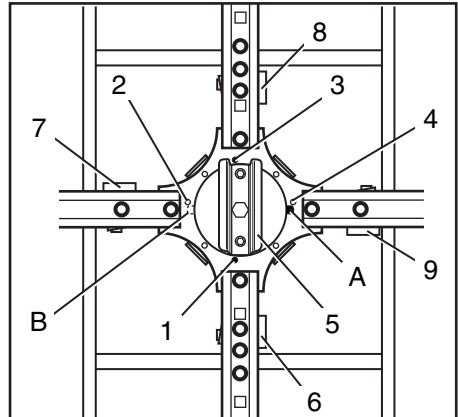

Fig. 24.2 Swivel plate

2. Guide the slide mechanism as far as the removable rail stop (24.2/6). The upward movement is blocked.
3. Open the removable rail stop (24.2/6) and slide the slide mechanism through the swivel plate up through the removable rail stop (24.2/8). The upward movement in the rail stop (24.2/8) is not blocked.
4. **Moving down:**
5. Guide the slide mechanism as far as the removable rail stop (24.2/8). The downward movement is blocked.
6. Open the rail stop (24.2/8) and guide the slide mechanism down through the swivel plate and through the removable rail stop (24.2/6). The downward movement in the rail stop (24.2/6) is not blocked.
7. **Going right when coming from above or below:**
8. Guide the slide mechanism up or down into the swivel plate, see point 1. or 4.
9. Turn the rail piece (24.2/5) clockwise from the vertical position to the right horizontal direction as far as the pin in the drilled hole (24.2/1).
10. Guide the slide mechanism to the right over the rail stop (24.2/9).
11. **Going up or down when coming from the right:**
12. Guide the slide mechanism from the right through the rail stop (24.2/9) into the rail piece of the swivel plate.
13. Turn the rail piece (24.2/5) anticlockwise from the horizontal position to the vertical direction until the rail piece is in line.
14. Move the slide mechanism up or down, see point 1. or 4.

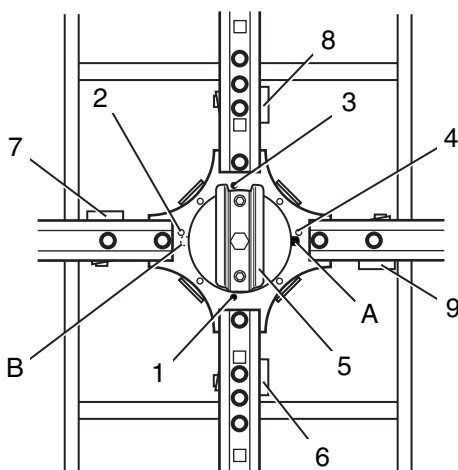

Fig. 24.3 Swivel plate

15. Turning left when coming from above or below:

- 16. Guide the slide mechanism up or down into the swivel plate, see point 1. or 4.
- 17. Turn the rail piece (24.3/5) anticlockwise from the vertical to the left horizontal direction as far as the pin in the threaded hole (24.3/3).
- 18. Guide the slide mechanism to the right through the rail stop (24.3/9).

19. Turning up or down coming from the left:

- 20. Guide the slide mechanism from the left through the rail stop (24.3/9) into the rail piece of the swivel plate.
- 21. Turn the rail piece (24.3/5) clockwise from the horizontal to the vertical direction until the rail piece is in line.
- 22. Move the slide mechanism up or down, see point 1. or 4.

NOTE

Due to the direction of pull through the rail stops (24.3/7) and (24.3/9), going from left to right or from right to left is only possible with a 180° turn of the slide mechanism in the swivel plate.

23. Moving from left to right:

- 24. Guide the slide mechanism into the rail piece (24.3/5) and turn the rail piece clockwise from the horizontal direction 180° as far as the pin in the threaded hole (24.3/1).
- 25. Move the slide mechanism to the right.

26. Moving from right to left:

- 27. Guide the slide mechanism into the rail piece (24.3/5) and turn the rail piece anticlockwise from the horizontal direction 180° as far as the pin in the threaded hole (24.3/3).
- 28. Move the slide mechanism to the left.

5.6 Using the folding rest platform

Lowering the rest platform

- When climbing from the bottom up, pass the rest platform so that the folding rest platform (25/1) can be lowered with the foot.

or

- When climbing from the top down, stop before the rest platform and lower the folding rest platform (25/1) with the foot.

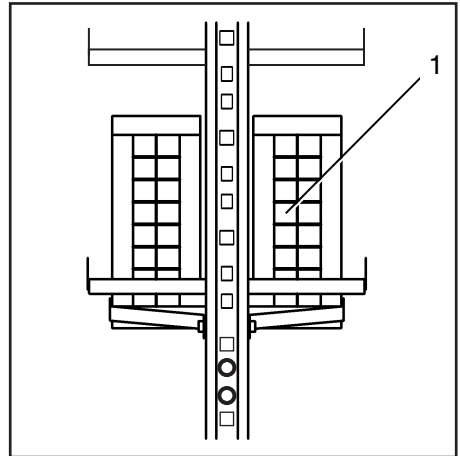

Fig. 25 Lowering the rest platform

Folding the rest platform back

- To fold the platform back, climb to the next higher rung and set the rest platform (26/1) to the vertical position with the foot.

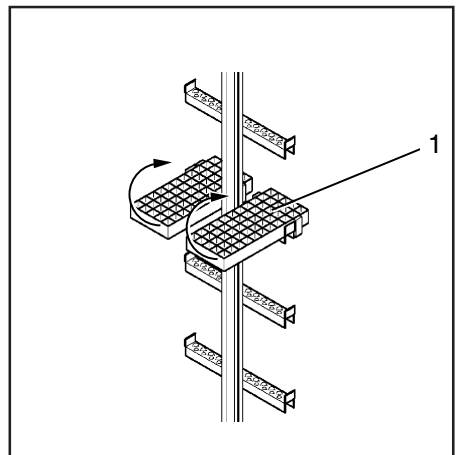

Fig. 26 Folding the rest platform back



6 MAINTENANCE, CARE AND STORAGE

6.1 Maintenance and care

- All components of the arrester system are maintenance-free.
- Clean or remove any remnants of dirt from the slide mechanism after each use.
- Clean the energy-absorbing strap element with little water and a small quantity of fine detergent. Do not use other cleaning agents (benzine, acetone, solvent, etc).
- The cleaned energy-absorbing strap elements may **only** be dried in a natural way and not with the direct rays of the sun, fire or other sources of heat.
- Before and after each use, check the pawl and the return spring of the slide mechanism for proper condition and ease of movement.
- If it is necessary to replace the energy-absorbing strap element, we recommend having the replacement carried out by ZARGES-Steigtechnik. If the energy-absorbing strap element is replaced by the user's skilled personnel/expert, the shackle pin must be installed with LOCTITE 638.

CAUTION Components which have been stressed by a fall must be taken out of operation and inspected by the manufacturer and repaired, if necessary.

- The energy-absorbing strap element must be replaced after 6 years of use. If doubts in respect to the proper operation of the energy-absorbing strap element arise during the annual inspection, the element must be replaced.
- The inspection intervals must be shortened if the energy-absorbing strap element is exposed to extreme temperatur fluctuations.



6.2 Storage

- The slide mechanism with energy-absorbing strap element must be stored so that:
 - influences of aggressive materials (acid, oil, etc.)
 - temperatures of 60 °C and over
 - temperature below -10 °C
 - direct exposure to light and UV radiation
 - moistureare excluded.
- A dry place, not too warm, is recommended as storage place. The slide mechanism should be stored hanging without a load.

6.3 Transport

- The slide mechanism must be transported by the user in a container protecting the slide mechanism from external influences (weather, mechanical damage etc.) during transport.

6.4 Packaging

- For storage and transport the slide mechanism must be packaged damp-proof, see Section 6.2 and 6.3.

7 RESCUE MEASURES

- The owner or the user must plan and establish measures for the rescue of the arrester system user before each use. For example, a second person should be detailed to act as observer.
- The user should not have to hang for a long time after a fall.



8 INSPECTIONS

- The user must inspect the slide mechanism and connecting parts for proper condition before each use.
- Check the retaining rings on the sliding mechanism axles for proper condition and security, replacing them if necessary.
- The owner is responsible for the personal protective equipment (slide mechanism) being inspected by an expert as required by the operating conditions or needs, but at least once a year.
- The owner is responsible for the arrester rail (with swivel plates and rest platforms) being inspected by an expert as required by the operating conditions or needs, but at least once every two years.
- The performance of the inspections must be recorded along with the results and subsequent actions. We recommend keeping an inspection log book in which all the data related to the arrester system is recorded. The inspection log book also contains instructions for the performance of the inspection and its documentation.

The inspection log book is available from ZARGES GmbH - Abteilung Schachttechnik/Steigleitern.

EC Certificate of Conformity

in the sense of EC directive 89/686/EEC, Appendix II A (personal protective equipment) and amended by directives 93/68/EEC, 93/95/EEC and 96/58/EC

The arrester system type

Make: ZARGES arrester system

Type designation: ZAST; with fixed guidance: Variant A: stainless steel rail, Variant B: galvanized steel rail; with sliding safety harness and energy-absorbing strap element developed, designed and manufactured in conformance with the aforementioned EC directives, at the sole responsibility of

Firma ZARGES GmbH.

The following harmonised standards are applied:

- DIN EN 353 part 1: 2002 -- Personal protective equipment against falls; arresters with fixed guidance
- DIN EN 362: 1993 -- Personal protective equipment against falls; connecting elements
- DIN EN 363: 2002 -- Personal protective equipment against falls; arrester systems
- DIN EN 365: 1993 -- Personal protective equipment against falls; general requirements for user manual and marking

The authority reported as responsible for the inspection of the ZAST arrester is:

Berufsgenossenschaftliche Institut for Arbeitssicherheit - BGIA
Alte Heerstraße 111

53754 Sankt Augustin

with the code number 0121 and

is involved for the

- storage of the documents acc. to Appendix VI of EC directive 89/392/EEC
- review of the correct application of the harmonised standards with approval of the prescribed documents specified in Appendix VI of EC directive 89/392/EEC
- **EC Type Test, Test Certificate No. 021048 of March 30, 2009**

.....
(Olav Beck), Product Manager, March 30, 2009



**Complete list of the basic requirements in respect to safety and health and the harmonising standards or other engineering specifications, which were taken into consideration when designing the personal safety equipment:
(acc. to Appendix II 89/686/EEC)**

Section acc. to Appendix II of 89/686/EEC	List of Requirements	Specified Section of Requirements
1.1	Design principles	4.1 DIN EN 353-1
1.1.1	Ergonomics	5.1 DIN EN 363
1.1.2	Level of protections and protection class	4.3, 4.5 DIN EN 353-1
1.1.2.1	Highest possible level of protection	
1.2	Harmlessness of the personal protective equipment	
1.2.1	Danger and disturbing influences of the personal protective equipment	4.1, 4.2 DIN EN 353-1
1.2.1.1	Suitable base materials	4.2 DIN EN 353-1
1.2.1.2	Suitable surface state of each part of the personal protective equipment coming in contact with the user	4.1 DIN EN 353-1 5.1 DIN EN 353-1
2.4	Personal protective equipment exposed to aging	4.2, 4.6, 6 DIN EN 353-1
3.1	Protection against mechanical impacts	
3.1.1	Impacts caused by falling or thrown objects and impact of a part of the body on an obstacle	4.5 DIN EN 353-1
3.1.2	Falling accidents	4.5 DIN EN 353-1
3.1.2.2	Prevention of falls from heights	4.5 DIN EN 353-1

SPACE FOR NOTES



ZARGES

SPACE FOR NOTES

